WATER INDUSTRY SPECIFICATION

WIS 4-32-08

June 2016: Issue 4

(Page 1 of 23)

UK Water Industry

SPECIFICATION FOR THE FUSION JOINTING OF POLYETHYLENE PRESSURE PIPELINE SYSTEMS USING PE80 AND PE100 MATERIALS

FOREWORD

Water supply companies and other entities deemed to be within the scope of the Public Procurement Directives are obliged to use BS EN 12201-1, BS EN 12201-2, BS EN 12201-3 and BS EN 12201-5 as their material specifications for the purchase of polyethylene (PE) pipe and fitting systems.

A consistent approach to field installation procedures for the materials so procured has not been published (i.e. EN 12201-6) and in its absence specifiers are directed to WIS 4-32-08 for guidance on UK installation practices involving butt fusion and/or electrofusion of PE systems.

This specification has been prepared by the UK Water Industry's Standards Board in consultation with the Water Industry and British Plastics Federation (BPF) Pipes Group.

This revision supersedes previous versions whilst addressing the following objectives:

- It recognises the use of BS EN 12201 (all parts) and aligns test methods and performance requirements with that standard to provide compatibility;
- It provides guidance on fusion jointing procedures for Type-A barrier pipes and fittings supplied in accordance with WIS 4-32-19;
- Larger PE pipe sizes and thicker wall sections are now in more widespread use requiring updates to the butt fusion parameters to be used;
- Pipes are increasingly of a multilayer design including single wall co-extruded PE and PE pipes with peelable outer protective layers;
- Adoption of ISO classification of materials wherein PE100 and PE80 are now used in place of HPPE and MDPE nomenclature.

NOTE: High productivity butt fusion jointing (known as UKWIR Fastweld) was developed for PE80 (MDPE) pipes. It is no longer used for water supply pipelines and is not included in this issue of the specification.

Compliance with this specification does not itself confer immunity from legal obligations. This specification does not purport to include all the necessary provisions of a contract. Users of this specification are responsible for its correct application.

Reference to a European Standard, British Standard, Water Industry Specification or any other specification applies equally to any equivalent specification. This specification includes the use of substances and/or procedures that may be injurious to health if adequate precautions are not taken. It refers only to technical suitability and does not absolve the user from legal obligations relating to health and safety at any stage.

It has been assumed in the drafting of this specification that the execution of its provisions is entrusted to appropriately qualified and experienced people. Operators are to be trained under a formal programme covering the execution of jointing procedures. Operators should be assessed for competence prior to undertaking such work and reassessed periodically thereafter.

Information contained in this specification is given in good faith. Neither Water UK nor BPF Pipes Group can accept any responsibility for actions taken by others as a result.

CONTENTS

	Foreword	1
	Contents	2
1.	Scope	2
2.	Manufacturer's responsibilities	2
3.	Equipment for butt fusion jointing	2
4.	Procedure for butt fusion jointing	4
5.	Equipment for electrofusion jointing	13
6.	Procedure for electrofusion jointing	14
7.	Quality Assurance	17
8.	Testing of joints	18
9.	References	19
	Appendix A Interpretation of butt fusion joint samples	20
	Appendix B Relationship between interface stress and gauge pressure	23

1. SCOPE

This document specifies the equipment and procedures for fusion jointing of polyethylene (PE) pipes and fittings.

This specification requires that the installer shall operate a quality assurance system, to BS EN ISO 9001, covering procedures for equipment provision, maintenance, servicing and calibration, record keeping, training and competency of personnel.

This specification covers the following pipe constructions commonly found in the UK:

- Single wall PE pipes (either PE80 or PE100) identifiable as being made from a single material in either light blue, dark blue or black through the full pipe wall.
- PE pipes with co-extruded layers where the pipe may comprise two or more layers of compatible PE materials, usually 2 layers with a black inner and a coloured thin outer layer.
- PE pipes with a removable outer layer that has to be peeled from the pipe before it is butt or electrofusion jointed.
- PE pipes with an aluminium barrier layer conforming to WIS 4-32-19, Type-A style, where the manufacturer permits butt fusion and/or electrofusion jointing of the system.

NOTE: PE80 in this context refers to pipes and fittings made from resin with a density in the range 930 kg/m³ to 940 kg/m³. No other pipes classed as PE80 are covered by this specification.

Competency is achieved through appropriate training, assessment, knowledge and experience to carry out the work being undertaken in a safe and proper manner. Users of this specification shall ensure that operatives engaged in the activities set out herein are competent to do so.

2. MANUFACTURER'S RESPONSIBILITIES

Manufacturers of PE pipes and fittings supplied in accordance with BS EN 12201 (all parts) have specific responsibilities to provide instructions on the correct jointing procedures.

Ordinarily, WIS 4-32-08 shall be used as the basis of selecting butt fusion parameters. Where a specific innovation that has not been anticipated by this specification occurs, then the manufacturer(s) of the pipe and of the jointing process shall advise and warrant the suitability of the technique.

Specification of butt fusion parameters for jointing pipe to spigot fittings, including factory made fabricated fittings is the responsibility of the fitting manufacturer.

Specification of the process and parameters for electrofusion is the responsibility of the fitting manufacturer. The manufacturer's instructions for use and/or recommendations prevail over the content of this WIS and shall be referenced.

Attention is drawn to the need to prepare the pipe prior to fusion jointing. The default position is to always scrape the pipe, however with the introduction of multilayer pipes alternative surface preparation may be required such as peeling or specialised surface removal tools. It is the responsibility of the pipe manufacturer to ensure suitable instruction is provided for such pipes.

3. EQUIPMENT FOR BUTT FUSION JOINTING

3.1 General

The butt fusion method of jointing requires an electrically heated plate to raise the temperature of the pipe ends to the fusion temperature and is suitable for jointing pipes and fittings in the size range greater than 63 mm. In general:

- Only pipes and fittings of the same diameter, SDR and material (PE80 or PE100) should be jointed together using butt fusion.
- PE80 pipes should not be butt fused to PE100 pipes.

3.2 Machine types

Fully automatic butt fusion machines shall be used for all sizes up to and including 630 mm. For sizes greater than 630 mm, fully automatic machines shall be used where they exist, otherwise a semi-automatic machine is permissible. Manual machines shall not be used.

Machine definitions:

- Fully automatic machines - where the parameters of time, temperature and fusion pressure are automatically calculated, controlled, logged and recorded by the machine.
- Semi-automatic machines - where the trimmer and heater plate are inserted / removed manually, interface pressures are controlled by an electro / hydraulic power pack and a data logger is used to record jointing parameters.
- Manual machines – where the trimmer and heater plate are inserted and removed manually and the interface pressures are controlled by a hand pump.

3.3 Machine requirements - all butt fusion jointing

3.3.1 General

All equipment for butt fusion jointing shall comply with the requirements of BS ISO 12176-1. This specifies the requirements for design of the machine chassis, trimmer, heater plate, temperature control and interface force transmission.

3.3.2 Chassis and Clamps

- The machine shall have a frame containing clamps which are sufficiently robust to re-round and accurately align the pipes to be jointed.
- The machine shall be properly aligned and capable of achieving the required jointing parameters. The rams shall move freely and control the movement of any sliding clamps. All

sliding clamps shall be kept free from rust and lubricated at all times.

3.3.3 Power unit

The unit shall be capable of actuating the clamp unit to provide adequate force and speed of operation. A monitoring device shall be provided to monitor ram pressure.

3.3.4 Trimming tool

- The trimming tool shall be capable of being mounted securely within the frame of the jointing machine to prevent lateral movement during machining so that this equipment can produce accurately matched, planed faces.
- All trimming tools shall be fitted with suitable safety devices to prevent their operation outside the fusion machine.
- Trimming blades shall be sharp and have defect free cutting edges to provide continuous swarf of uniform thickness.

3.3.5 Heater plate

- The plate shall be electrically heated and be provided with a suitable temperature controller to give a uniform operating surface temperature of 230 °C \pm $\frac{+10}{-5}$ °C (i.e. 225 °C to 240 °C).
- The plate surfaces shall have adequate release properties. The surface shall clearly show the presence of any contaminants. ADDITIONAL SPRAY-ON RELEASE AGENTS SHALL NOT BE USED.
- The heater plate shall be fitted with a temperature probe or indicator accurate to within \pm 2 °C in the range 225 °C to 240 °C.
- Surface temperature shall be measured during routine calibrations and in cases of dispute. To ensure that the temperature of the heater plate has stabilised, the machine shall be in operation with the plate in its guard or muff for at least twenty minutes prior to measurement. The probe shall be held in position for at least sixty seconds before the reading is taken. Site readings shall be taken inside a shelter.
- All readings shall be taken from the operational area of the plate (i.e. the area covered by largest pipe OD and smallest pipe ID) within the machines range. All readings shall be within the temperature range 225 °C to 240 °C.

NOTE 1: A non-contact infra-red temperature gun may be used for routine measurements, but in the case of disputes a contact thermocouple should be used against the surface of the plate.

NOTE 2: The temperature of each side of the plate should be measured, in still air, at a minimum of four equally spaced points denoted North, South, East, West (with North at the top of the plate) for pipes up to 250 mm diameter, eight equally spaced points up to 630 mm diameter, and sixteen equally spaced points for all larger systems.

NOTE 3: The probe could scratch or otherwise mark the surface of the heater plate if used carelessly. Readings may therefore be taken just outside the position where the pipe contacts the heater plate.

3.3.6 Control system

- a) The control system shall be designed to carry out the operations detailed in Figures 2 and 3 (see 4.7 of this specification), automatically at the temperatures, times and pressures indicated in Tables 1 and 2.
- b) The control system shall include a data capture system that uniquely identifies each joint made and the parameters specified and achieved when jointing. A change in timescale will be needed to capture dwell time with sufficient accuracy. The ram area and calculation of actual jointing pressures shall also be recorded.
- c) Subject to the provisions of the Data Protection Act, it is preferable that the machine includes provision to record operator identification to be associated with the site records. In any event, the installer shall maintain such records as are needed to identify the operative responsible for each butt fusion joint.

NOTE: The ram area and calculation of actual jointing pressures are pre-programmed into automatic machines.

3.3.7 Generators

The nominal output voltage should be 110 V with an actual output voltage within the range 103 V – 120 V at any kVA loading between zero load and full load. The generator shall be selected to suit the butt fusion machine power requirements.

NOTE 1: For equipment operating at higher voltages, appropriate health & safety risk assessments should be carried out and site practice / protocols should be established.

NOTE 2: Contractors should always seek the advice of the machine supplier for information on power requirements.

3.4 Ancillary Equipment

In addition to the butt fusion machine and generator, the contractor shall also supply site crews with:

- shelters to provide protection for pipe, fittings and equipment against dust, rain, snow and draughts;
- pipe support rollers (essential to minimise drag forces);
- external bead remover capable of removing the cold bead cleanly, in a continuous strip, without damage to either joint or bead or adjacent areas of the pipe. The bead removal tool shall not induce any slits, gouges or other defects into the pipe wall;
- where specified by the asset owner, an internal bead remover (the type/model and process for its use to be agreed by the contracting parties);
- calibrated digital thermometer to the accuracy and resolution given in 3.3.5;
- pipe end plugs;
- bead gauge;
- indelible marker pen for marking beads and joint numbers; and
- clean ground sheet or base board.

4. PROCEDURE FOR BUTT FUSION JOINTING

4.1 Definitions (listed alphabetically)

Cooling pressure

the gauge pressure required to provide, on a given machine and for a given pipe cross sectional area, the appropriate interface stress to be maintained during the cooling phase.

Drag pressure

the gauge pressure required to overcome, on a given machine and for a given pipe length / cross sectional area, the sliding frictional drag of the moving half of the machine and pipe when closing.

NOTE: Gauge pressure is a function of the efficiency of each machine, which should be provided by the manufacturer, along with ram dimensions.

Fixed half of machine

the side of the machine where the chassis is fixed. When assembling pipe strings, the completed pipe joints should be moved along onto the fixed side of the butt fusion machine.

NOTE: If a long pipe length or string is loaded into the moving half, it may result in a higher drag pressure being applied than the jointing pressure.

Fusion pressure

the gauge pressure to provide, on a given machine and for a given pipe cross sectional area, a pressure equivalent to the interface fusion stress.

NOTE: This pressure is a function of the ram dimensions and the efficiency of the machine and this data should be given on the data plate of all, except fully automatic, machines.

Gauge pressure

the pressure on the cylinder of a hydraulically powered butt fusion machine. For relationship between interface stress and gauge pressure, see Appendix B.

Heater plate temperature

the temperature at any location on the surface of the heater plate.

Initial bead-up pressure

the gauge pressure required to provide, on a given machine and for a given pipe cross sectional area, an interface fusion stress of 0.15 MPa and thereby form the initial bead on the ends of the pipes.

Interface fusion stress

the actual stress exerted on the heater plate by the pipe ends during both bead-up and during jointing and cooling.

Jointing pressure

the sum of the fusion pressure and the drag pressure.

Moving half of machine

the side of the machine where the chassis moves. The hydraulic rams control the applied force (pressure) for jointing and cooling. The shortest pipe length to be joined should be loaded into the moving half to minimise drag pressure.

Plate removal time

the maximum time permitted for the separation of the pipe ends from the heater, removal of the heater plate and closure of the carriage to bring the two pipe ends together.

Pressure Increase Time (Ramp)

the time / rate, directly following the heater plate removal time, at which the pressure is increased from

zero to the interface fusion stress for the pipe being welded.

Soak pressure

the gauge pressure required, on a given machine and for a given pipe cross sectional area, to positively maintain the pipe in contact with the heater plate.

4.2 Siting the equipment

a) To aid alignment of pipes into the machine and for ease of movement, pipes to be jointed shall always be supported on rollers placed at suitable intervals to minimize drag and the effect of pipe sagging between them.

b) The butt jointing machine shall be placed on a clean, level and firm surface.

NOTE: If necessary the jointing machine should be placed on a suitable baseboard or ground sheet.

c) Pipe strings shall be laid out on a level surface where possible. If the pipe string is on a slope, particular care shall be taken when measuring and controlling machine ram pressures to ensure that consistent results are obtained.

4.3 Preparation

a) PE pipes with a removable outer skin (that has to be peeled away before jointing) can be joined by butt fusion. Tooling detailed in the manufacturer's technical data file shall be used and manufacturer's guidance on the amount of material to remove followed. No polymer material other than PE80 or PE100 should be brought into contact with the heater plate.

b) Type-A barrier pipes conforming to WIS 4-32-19 can be joined by butt fusion provided the outer layers, including the aluminium, are stripped back from the pipe end. Tooling detailed in the manufacturer's technical data file shall be used and manufacturer's guidance as on the amount of material to remove followed.

NOTE 1: Co-extruded PE pipes should be treated as single wall PE pipes when joining by butt fusion. No additional procedures or precautions are necessary.

c) The trimming tool surfaces shall be visually inspected every day for grease and dirt and

cleaned where necessary in accordance with the materials described in 4.3 (e) below.

- d) Particular attention shall be paid to the condition of the blades. Blunt or damaged blades shall be replaced.

NOTE 2: Care should be taken when handling sharp blades.

- e) Only clean, disposable, lint-free materials shall be used to clean the plate. Grease and oily films are not fully removed by using water, therefore wiping with a clean, lint-free cloth or cleaning material dampened by isopropanol may be necessary. When using solvents for cleaning, the plate shall be cold to prevent rapid evaporation and avoid unnecessary fumes.
- f) Although cleaning will remove large patches of dirt, very fine particles of dust may still accumulate within the hollows of the textured surface of a heater plate. To remove such dust, a dummy joint shall be made at the start of each jointing session, whenever the plate has been allowed to cool below 180 °C, or at a size change.
- g) A second dummy joint shall be made for sizes greater than 180 mm. The procedure to be adopted is:
- A dummy joint may be made using pipe off-cuts of the same size, SDR and material as the pipe being installed. Alternatively, lengths of pipe which are to be installed may be used for this procedure, providing the pipe ends are allowed to cool for at least ten minutes before re-trimming to make the production joint.
 - Follow the normal trimming, bead-up and full soak time routine for jointing (see 4.5 of this specification).
 - For automatic machines the procedure can be discontinued after the full heat soak cycle providing the machine automatically stores the parameters for verification. Otherwise, a full joint shall be made and cut out as proof that a dummy joint has been done.
- h) Prior to clamping in the butt fusion machine, the ends of the pipes (in excess of the clamping area) shall be wiped with clean, damp lint free material or prescribed 'wet wipe' on both inner and outer surfaces to remove mud or dust. When using isopropanol wet wipes, a minimum of six minutes should be allowed for evaporation before proceeding.
- i) If not using isopropanol wet wipes, the pipe shall be wiped dry prior to proceeding.
- j) To prevent contamination, the pipe ends shall not be handled thereafter.

4.4 Pre-jointing checks

Prior to jointing, the following shall be checked:

- a) The equipment is correctly sited (see 4.2 of this specification).
- b) There is sufficient fuel for the generator to complete the joint and the generator is started before connection to the machine to check that it is functioning correctly.
- c) The trimming tool, hydraulic pump and heater plate are clean and in working order (see 4.3 of this specification).
- d) Both pipes or pipe and fitting to be jointed are of the same size, SDR and material (PE80 or PE100). Only compatible materials shall be jointed together.

NOTE 1: If in doubt, the advice of the pipe or fitting manufacturer should be sought.

NOTE 2: The drag pressure should normally be less than the fusion pressure. Where the drag pressure is higher than the fusion pressure, then this may lead to a poor quality joint.

NOTE 3: Drag pressure is automatically measured when fully automated butt fusion jointing machines are used.

4.5 Jointing Procedure

4.5.1 General

Throughout all stages of the butt fusion process, the operator shall continuously check that the pipe does not move within the clamps.

NOTE: For semi-automatic machines, this may require placing a mark on the pipe.

4.5.2 Trimming

- a) For PE pipes with a removable skin and PE barrier pipes, the pipe manufacturer's instructions shall be followed with regard to the length of outer layer(s) to be removed and the correct method of removal in accordance with 4.3 of this specification. Attention is drawn to the need, after this trimming stage is completed, for sufficient exposed pipe end to remain in accordance with the manufacturer's declaration to avoid interference in the butt fusion process.
- b) The pipes in the clamps shall be positioned with ends adjacent to the trimming tool and with pipe printline markings aligned. This will assist in obtaining the best match for to correct for pipes that are 'out of round'. Pipes shall be jointed so

that the pipe markings are uppermost when the pipe is in the trench.

- c) The pipe clamps shall be tightened to grip and re-round the pipes.
- d) The free pipe ends shall be covered to prevent cooling of the plate by internal draughts.
- e) The trimming tool shall be switched on and the pipe ends moved against the trimmer with a steady pressure until at least three rings of continuous shavings are produced from each of the pipe ends.
- f) Once the trimming tool has come to a halt, it shall be removed from the chassis and loose shavings pulled out from the bottom of the machine to avoid drawing contaminated shavings back across the prepared ends. **DO NOT TOUCH THE MACHINED FACES OF THE PIPE OR FITTING** as this will contaminate the joint interface.
- g) The pipe or fitting faces shall be checked for complete trimming and re-trim if necessary.
- h) The pipe or fitting ends shall be brought together and checked that there is no visible gap between the faces. The mismatch of the outside pipe diameter shall be within the following limits:
 - Less than 1 mm up to and including 180 mm.
 - Less than 10 % of wall thickness above 180 mm.
- i) If the mismatch is greater than that stated above then the pipe shall be realigned and re-trimmed.

4.5.3 Bead up

The pipe shall be pressed against the heater plate using the appropriate initial bead-up pressure for the chosen method of jointing (see 4.7 this specification).

NOTE: The initial bead should be uniform around the circumference and be of a width similar to those given in Table 1 or 2 as appropriate.

4.5.4 Heat Soak

After the initial bead up, the pressure in the system is released so that the pressure gauge registers between zero and the drag pressure to control bead growth during heat soak time.

4.5.5 Plate removal

- a) During removal of the heater plate, no molten polymer shall stick to the heater plate. If it does then the joint shall be aborted, the plate cleaned and the surface quality of the plate examined.
- b) The heater plate shall be removed and the molten ends brought together within the specified time for the chosen method of jointing (see 4.7 of this specification). If this criterion is not met then the joint shall be aborted.
- c) The plate removal time shall be less than ten seconds.

4.5.6 Fusion jointing

Immediately after plate removal the hot pipe ends shall be brought together in a smooth controlled manner and the pressure raised to the interface fusion pressure for the chosen method of jointing (see 4.7 of this specification) with a controlled pressure increase time (ramp).

NOTE 1: The fused material should “roll” back in a uniform manner and there should be no signs of bubbles or contamination present.

4.5.7 Cooling

The joint shall be cooled in the machine for the full ‘cooling time in clamps’ whilst maintaining the interface fusion stress (see 4.7 of this specification).

NOTE 1: In previous editions of this specification the principle of cooling time in clamps and cooling time out of clamps was permitted. Based on research to improve the quality of joints in thick walled pipe, this practice is no longer accepted and a single cooling time is now specified wherein it is better suited to site handling without affecting joint integrity. This is reflected in Table 2.

NOTE 2: Any cover or plug used to block the ends of the pipe may be removed to promote a draught through the pipe to assist cooling once the cooling time has commenced.

4.5.8 Bead Appearance

The external beads shall have no wrinkles or discontinuities and be of symmetrical appearance.

NOTE: The uniformity of the fusion joint bead should be checked around the full circumference of the pipe. Provided that each half of the final bead is of a similar shape and size, the overall width should not be a critical factor for the assessment of a butt fusion joint – hence the bead sizes quoted in Tables 1 and 2 are typical only. Non-uniform beads indicate that the equipment is not set up correctly; or the pipe mismatch is beyond acceptable limits; or the pipe is not being uniformly heated by the heater plate.

4.5.9 Debeading

- a) After the cooling time has elapsed, the external bead shall be removed using a purpose designed tool approved by the client. The bead removal tool shall not induce any slits, gouges or defects in the pipe wall or bead.
- b) Following bead removal, the underside surface where it has been trimmed off the pipe shall be inspected. Examination of this area provides an indication of joint quality. The bead shall be visually examined to check for contamination in the material and for slit defects or splitting along the length of the bead joint. Slit defects of concern will have a brittle or 'glass like' appearance.
- c) Following visual examination, a bend back test shall be performed. The bead is bent over and twisted (see Figure 1) in sufficient positions along the full length of the bead (maximum 100mm spacing) to induce further stress along the joint interface. If the bead splits in a brittle or 'glass like' manner, this will be classed as a defect.



Figure 1: Identifying defects in external beads, brittle split evident on twisting

- d) If such a defect or split is seen then the joint shall be cut from the pipeline and the joint remade. If a similar defect recurs, all further production jointing shall cease until the equipment has been thoroughly examined, problems rectified and new trial joints made and tested.

- e) The beads and joint shall be numbered / coded using an indelible marker pen to ensure direct identification of each bead with each joint.
- f) After the cooling time has elapsed, the internal bead shall be removed if that has been specified by the client. The tool used shall be approved by the client. The removal of the internal bead shall not induce any slits, gouges or defects on the surface of the pipe.

NOTE: For water/sewage transmission, the internal bead will not significantly affect the flow properties. Thus, there is no need to remove the bead to improve hydraulic characteristics. However, sticks and fibrous material can be trapped by internal beads in pumped sewerage mains.

4.6 Butt fusion jointing at very low ambient temperatures

- a) Where butt fusion jointing is conducted at ambient temperatures below 0 °C, a space heater shall be provided for the shelter to raise the local temperature above 0 °C, preferably above 5 °C to prevent icing of the machine chassis and thickening of hydraulic control fluids.
- b) Test joints shall be made in accordance with 8.2 of this specification to establish whether satisfactory joint integrity is maintained. All tensile test samples shall fail in a ductile manner. If it is suspected that the low temperature has caused joint embrittlement, then the average heater plate temperature should be increased to the upper limit specified (240 °C). Further checks shall then be made to ensure that satisfactory joint performance is achieved.
- c) Fusion jointing machines with control systems that do not intrinsically compensate for ambient temperature changes shall demonstrate effective compensation operation through a defined appropriate test program as agreed by the client utility or his appointed representative.

4.7 Parameters specific to jointing method

4.7.1 Single pressure butt fusion jointing for pipe wall thickness up to 22mm

- a) Single pressure butt fusion is suitable for jointing pipes with wall thickness up to 22 mm.
NOTE: This equates to 90 mm to 400 mm, SDR 17 for standard pipes but will be extended for thin wall PE lining pipes.
- b) For single pressure butt fusion, the interface stress is (0.15 ± 0.02) MPa throughout the jointing

process (initial, bead-up, fusion, cooling - see Figure 2).

4.7.2 Dual pressure butt fusion jointing

- a) Dual pressure butt fusion jointing shall be used for all thicker walled (>22 mm) PE pipes to enhance ductility.

NOTE : The objective of dual pressure butt fusion is to allow the molten polymer to cool with minimal shear stress, thus allowing the crystal structure to develop without distortion. It is recognised that there are some materials for which conventional 'single pressure' conditions are satisfactory for all sizes of pipe. However, with certain PE100 materials the polymers may be more crystalline. The polymer can have a coarse crystal structure, and the region between the molten and solid PE material can become shear-distorted when force is applied during cooling. This region can then reduce overall ductility in the joint area.

- b) The 'Dual Pressure' cycle (see Figure 3) is the same as for single pressure until the plate is removed, at which point:
- Apply the "conventional" interface fusion stress of 0.15 MPa for 10 s after bringing the pipe ends together to allow the melt on each surface to mix and a bead to form. This clears any contaminants from the interface.
 - Reduce the interface fusion stress to 0.025 MPa during cooling.
- c) For typical UK ambient temperatures, the recommended heat soak time is $[(12.5e)/60 + 1]$ min, where e is the wall thickness (mm).

NOTE 3: For low ambient temperatures (below - 5 °C) and thick walled pipes, the heat soak time may need to be increased.

NOTE 4: Where e is the wall thickness (mm), the minimum cooling time in the machine under pressure is $(0.015e^2 - 0.47e + 20)$ min. at an interface stress of 0.15 ± 0.02 MPa and an ambient temperature of $23 \pm 2^\circ\text{C}$.

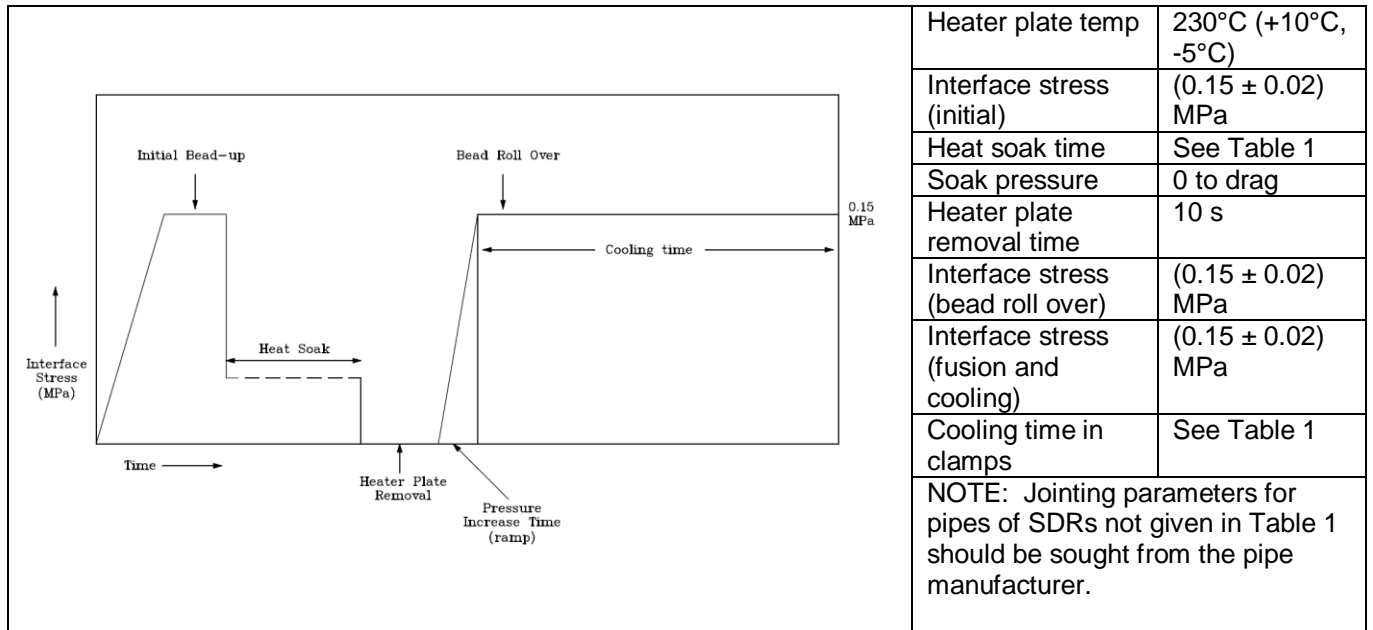

Figure 2 Single pressure butt fusion jointing cycle (not to scale)

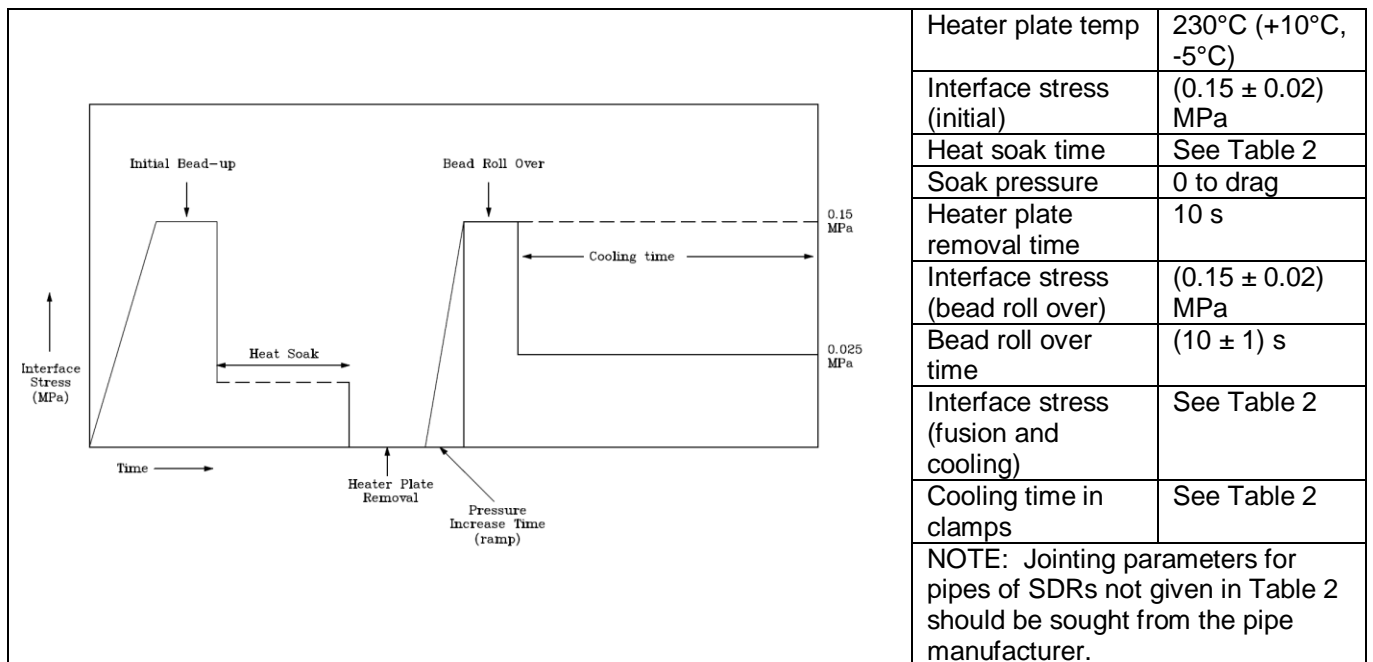

Figure 3 Dual pressure butt fusion jointing cycle (not to scale)

Table 1 Single Pressure Butt Fusion Jointing Conditions for PE80 and PE100

Outside diameter	SDR	Wall thickness (min)	Interface stress (initial)	Initial bead size (approx.)	Minimum heat soak time	Minimum soak pressure	Heater plate removal time	Interface stress (fusion and cooling)	Cooling time in clamps	Additional cooling time for coiled pipes	Typical final overall bead width (min)	Typical final overall bead width (max)
(mm)		(mm)	(MPa)	(mm)	(s)	(MPa)	(s)	(MPa)	(min)	(min)	(mm)	(mm)
90	17	5.1	0.15	2	110	0	10	0.15	15	5	8	15
90	11	8.2	0.15	2	140	0	10	0.15	15	5	9	16
110	17	6.3	0.15	2	125	0	10	0.15	15	5	9	16
110	11	10.0	0.15	2	160	0	10	0.15	15	5	10	17
125	17	7.1	0.15	2	130	0	10	0.15	15	5	9	16
125	11	11.4	0.15	2	175	0	10	0.15	15	5	10	17
160	17	9.1	0.15	2	150	0	10	0.15	15	5	9	16
160	11	14.6	0.15	2	205	0	10	0.15	15	5	11	18
180	17	10.2	0.15	2	160	0	10	0.15	15	5	10	17
180	11	16.4	0.15	2	225	0	10	0.15	15	5	11	18
225	17	12.8	0.15	2	190	0	10	0.15	15	-	10	17
225	11	20.5	0.15	2	265	0	10	0.15	15	-	12	19
250	26	9.6	0.15	2	155	0	10	0.15	15	-	9	16
250	17	14.2	0.15	2	200	0	10	0.15	15	-	10	17
280	26	10.7	0.15	2	170	0	10	0.15	15	-	13	22
280	17	15.9	0.15	2	220	0	10	0.15	15	-	14	23
315	26	12.1	0.15	2	180	0	10	0.15	15	-	13	22
315	17	17.9	0.15	2	240	0	10	0.15	15	-	14	23

Table 2 Dual Pressure Butt Fusion Jointing Conditions for PE80 and PE100

Outside diameter	SDR	Wall thickness (min)	Interface stress (initial)	Initial bead size (approx.)	Minimum heat soak time	Minimum soak pressure	Heater plate removal time	Interface stress (fusion and cooling)	Interface stress (cooling after 10 s)	Cooling time in clamps	Typical final overall bead width (min)	Typical final overall bead width (max)
(mm)		(mm)	(MPa)	(mm)	(min)	(MPa)	(s)	(MPa)	(MPa)	(min)	(mm)	(mm)
250	11	22.7	0.15	2	6	0	10	0.15	0.025	18	15	24
280	11	25.4	0.15	3	7	0	10	0.15	0.025	18	16	25
315	11	28.6	0.15	3	7	0	10	0.15	0.025	19	17	26
355	11	32.2	0.15	3	8	0	10	0.15	0.025	21	18	27
400	17	23.7	0.15	3	6	0	10	0.15	0.025	18	15	24
400	11	36.3	0.15	3	9	0	10	0.15	0.025	23	18	27
450	17	26.7	0.15	3	7	0	10	0.15	0.025	19	16	25
450	11	40.9	0.15	3	10	0	10	0.15	0.025	26	19	28
500	17	29.7	0.15	3	8	0	10	0.15	0.025	20	17	26
500	11	45.4	0.15	3	11	0	10	0.15	0.025	30	20	29
560	17	33.2	0.15	3	8	0	10	0.15	0.025	21	17	26
560	11	50.8	0.15	3	12	0	10	0.15	0.025	35	22	31
630	26	24.1	0.15	3	7	0	10	0.15	0.025	18	16	25
630	17	37.4	0.15	3	9	0	10	0.15	0.025	24	18	27
630	11	57.2	0.15	3	13	0	10	0.15	0.025	43	23	32
710	26	27.2	0.15	3	7	0	10	0.15	0.025	19	16	25
710	17	42.1	0.15	3	10	0	10	0.15	0.025	27	19	28
800	26	30.6	0.15	3	8	0	10	0.15	0.025	20	17	26
800	17	47.4	0.15	3	11	0	10	0.15	0.025	32	20	29
900	26	34.4	0.15	3	9	0	10	0.15	0.025	22	18	27
900	17	53.3	0.15	3	13	0	10	0.15	0.025	38	22	31
1000	26	38.2	0.15	3	9	0	10	0.15	0.025	24	19	28
1000	17	59.3	0.15	3	14	0	10	0.15	0.025	45	23	32
1200	26	45.9	0.15	3	11	0	10	0.15	0.025	31	31	30
1200	17	71.1	0.15	3	16	0	10	0.15	0.025	63	26	35

5. EQUIPMENT FOR ELECTROFUSION JOINTING

5.1 General

Electrofusion fittings are manufactured and tested to BS EN 12201-3.

This method of jointing uses electrofusion fittings containing electrical wires which, when connected to the appropriate power source, fuse the fitting onto the pipe without the need for additional heating equipment.

For Type-A barrier pipes conforming to WIS 4-32-19, only those fittings which are third party approved to WIS 4-32-19 for use with that specific pipe shall be electrofusion jointed.

The effectiveness of this technique depends on attention to effective preparation of the jointing surfaces, in particular the removal of the oxidised surface of the pipe over the jointing area and ensuring the jointing surfaces are clean.

Mechanical pipe end scrapers (e.g. rotary scrapers) shall be used when preparing pipe ends for electrofusion socket jointing. Hand scraper tools may be used for saddle fitting preparation provided that such tools are in good condition with a sharp edge able to remove sufficient material across the pipe surface.

With electrofusion saddle jointing, an electrical resistance element is incorporated in the base of the saddle (tapping tees or branch) which when connected to an appropriate power source, melts and fuses the materials of the pipe and fitting together.

The success of this technique, as with socket jointing, depends on effective preparation of the jointing surfaces, in particular the removal of the oxidized surface of the pipe over an area at least equivalent to the saddle base.

Three methods of holding the tapping tee / branch saddle during the fusion cycle are used:

- top loading;
- under clamping; and
- wrap-around systems.

Because of the variations of equipment used for under clamping and wrap around, common procedures for holding the saddle during the fusion cycle cannot be specified, although the general parameters are similar to those for top loading. Where such fittings are used, the manufacturer's procedure for holding the fitting during the fusion cycle shall be followed.

5.2 Machine requirements – control box

- a) The control box input supply shall be from a nominal 110V (55V – 0 – 55V) generator of a suitable capacity based on the manufacturer's instructions. The nominal output of the generator shall be $110\text{ V } \frac{+25}{-10}\%$ between no load and full load.
- b) The control box and generator shall be of sufficient power to fuse the applicable fittings.
NOTE: A 'matched pair' control box and generator should be requested from suppliers or hirers.
- c) Extension leads shall not be used on the control box outlet connectors.
- d) Control boxes shall comply with the requirements of BS ISO 12176-2.
- e) Control boxes shall have data retrieval to ensure full traceability of jointing/site practices.
- f) Control boxes are not 'intrinsically safe' and shall not be taken into any trench. If this cannot be met in large excavations, a thorough risk assessment shall be required prior to operations.

5.3 Ancillary Equipment

In addition to the control box and generator, the contractor shall also supply site crews with ancillary equipment to be used as follows:

- a) Pipe re-rounding clamps to re-round the pipe ends prior to pipe preparation. Such tools are mandatory for joints made to coiled pipe ends in particular to ensure the 'out of round' pipe end is sufficiently corrected to enable insertion into the fitting socket end.

NOTE 1: Some coiled pipes (notably 160 mm and 180 mm SDR 11 and SDR 17) may be too oval to fit couplers, or the radius of curvature of the pipe may make alignment of the ends impossible. It is recommended that a pipe straightening tool or re-rounding clamps are used.

- b) Rotary pipe scrapers shall be capable of removing the oxidised surface of the pipe over more than the insertion length before welding is attempted. The tool shall remove a layer 0.2 mm to 0.4 mm thick from the outer surface of the pipe. The scraper shall remove a continuous strip of swarf over the insertion length and round the pipe.

NOTE 2: Hand scrapers are permitted for locations where it is not possible to use a rotary scraper e.g. for electrofusion saddle connections.

- c) Pipe re-rounding clamps shall be used to correct 'out of round' pipe ends (whether in stick or coil form) to enable insertion into the round electrofusion sockets. Additionally, alignment clamps shall be used to hold the pipe ends in the fitting and shall ensure the pipes are held in a fixed position without movement throughout the fusion and cooling periods. Pipe re-rounding and pipe alignment clamps shall be of robust construction. Clamps of either type using webbing straps for re-rounding or restraint shall not be used.
- d) A shelter shall be used to provide protection for pipe, fittings and equipment against dust, rain, snow and draughts.
- e) The contractor shall ensure the pipe ends are cut square.
- f) An indelible marker pen shall be supplied for marking insertion depths and hatching the fusion area to be prepared.
- g) A clean baseboard or groundsheet shall be supplied and used.

6. PROCEDURE FOR ELECTROFUSION JOINTING

6.1 Sockets

6.1.1 Pre-jointing checks

Prior to jointing, the following shall be checked:

- a) There is sufficient length of pipe spigot on each end of the fitting to enable mechanical scraping and the fitting of the re-rounding and restraint clamps.

NOTE 1: The lengths specified for spigoted fittings in BS EN 12201-3 are quite short and it is advised that spigoted fittings be specified with factory butt fused "pups" of suitable length when purchasing.

- b) There is sufficient space all round the pipe to permit access to the pipe ends. In a trench, a minimum clearance of 150 mm is required all

round. Larger clearances may be needed for larger nominal sizes.

- c) Any excess standing water has been removed. Avoiding the risk of contaminating the pipe end takes less time than cleaning away the mud and moisture afterwards.
- d) Contamination of prepared surfaces is prevented by using a ground sheet or a suitable board to cover the ground under the joint. Where appropriate, make use of a portable shelter to protect the joint against rain or wind-blown dust.
- e) All required ancillary equipment is available (see 5.3).
- f) There is sufficient fuel for the generator to complete the joint and the generator is started before connection to the electrofusion control box to check that it is functioning correctly. The electrofusion control box shall display a valid calibration label.
- g) The connectors at the end of the control box leads are clean and undamaged.
- h) The pipe and fittings are the same size. The manufacturer's delivery label should be checked for fitting suitability.

NOTE 2: The overall pressure rating of the installed system is that of its lowest pressure rated component.

- i) The terminals of the leads from the electrofusion control box are the correct size for the terminals of the electrofusion fittings. Both 4.0 mm and 4.7 mm terminal pins are in widespread use.

6.1.2 Preparation – pipe surface

Preparation of the pipe by removal of a thin layer of material gives the cleanest surface for jointing.

Electrofusion jointing shall be one continuous process with the pipe surface prepared immediately before jointing as follows:

- a) The pipe shall be checked for any abrasions or impact damage that may be detrimental to the performance of the joint. The pipe ends to be jointed shall be cut square to the axis and burrs removed.
- b) For PE pipes with a removable skin and PE barrier pipes, follow the pipe manufacturer's instructions with regard to the length of outer layer(s) to be removed and the correct method of removal.

- c) Before pipe surface preparation, the pipe ends shall be washed down (in excess of the clamping area) to remove traces of dirt or mud. Where wet wipes are used, they shall comply with the requirements of 6.1.3 (c).
- d) Using a marker pen, the desired final position of the end of the fitting shall be marked on the pipe.
- e) Using the pipe end preparation tool, remove a thin layer of 0.2 mm to 0.4 mm uniformly from the entire surface of the pipe, preferably as a continuous strip of swarf over the area identified, i.e. in excess of penetration depth. Once prepared, the pipe surfaces shall never be touched and may benefit from wrapping in a clean, dry polythene bag secured with adhesive tape.

NOTE 1: The electrofusion fitting should be placed on the pipe immediately after preparation of the pipe surfaces by scraping (or other method of preparation, see Note 2). Where there is more than one pipe end to prepare, the fitting should still be placed on the pipe end but remain protected by its delivery bag.

NOTE 2: PE pipe with removable skin should be prepared using the tooling and method provided by the pipe manufacturer. Unapproved tooling may damage the pipe. If during the skin removal process or before the electrofusion fitting is placed on the pipe, the pipe surface becomes contaminated then treat the pipe as a conventional PE pipe and prepare the surface using a rotary or hand scraping tool.

- f) The area over which the oxidised surface is to be removed shall be marked in excess of the penetration depth on each pipe to be jointed by placing the socket of the bagged fitting alongside the pipe end. A line shall be traced round the circumference at the appropriate distance from the pipe end and the area hatched using a suitable marker.
- g) Pipe ovality, particularly on coiled pipes, can have a detrimental effect on the integrity of electrofusion joints on both socket and saddle type fittings. It is recommended that the pipe profile within the area to be jointed is re-rounded prior to fusion to within the limits of ovality prescribed by BS EN 12201-3 by means of tools designed specifically for this purpose.

6.1.3 Preparation – removal of contamination

- a) The pipe end shall be freshly scraped immediately prior to assembly and jointing.

NOTE 1: Scraping of pipe ends and immediately covering with the fitting which is to be jointed is the preferred work practice.

- b) If dust contamination or mud (dry or wet) has settled on the pipe surface to be jointed after it has been scraped, prior to assembly, a wad of fresh unused 'wet wipes' (see 6.1.3(c)) shall be used to remove contamination. A separate 'wad' of wet wipes shall be used for each surface and shall then be discarded. Surfaces shall be allowed to dry completely prior to fusing.

NOTE 2: Wet wipes used inappropriately (e.g. wipe used with dirty hands / gloves, wet wipes used multiple times) can spread contamination around a joint so attention is drawn to installers to use a fresh wipe to remove contamination and ensure it is 'scrunched' or 'balled' to prevent dirt transfer from gloves to the pipe surface for example.

- c) The wet wipe shall be a pre-impregnated lint free cloth which has been soaked in a 90% isopropanol: 10% water mixture. No other solvents, detergents or cleaning agents shall be added.
- d) No attempt shall be made to clean fittings or prepared pipe surfaces that have become heavily contaminated with mud or water. When contamination cannot be removed the fitting or prepared pipe surface shall be discarded.

6.1.4 Joint assembly and clamping

- a) One pipe end shall be prepared (see 6.1.2 of this specification) and immediately after preparation of the pipe surface by scraping, one end of the fitting bag shall be opened and the pipe inserted into the fitting so that it is in contact with the centre stop. If the fitting does not have a centre stop, then the pipe shall be inserted to the depth mark previously applied. The second pipe end shall be prepared and repeat.
- b) Once the pipes are inserted correctly into the fitting, the insertion depth on the pipe shall be

marked (if not done already or if the marks have become unclear due to scraping) and placed into the restraining clamps.

- c) Clamps shall always be used to secure the pipe ends so that during the fusion cycle they cannot move within the fitting.
- d) The pipe ends and the fittings shall be visually checked to ensure that they are correctly aligned.
- e) Once prepared or debugged, the surfaces to be fused shall not be touched.

6.1.5 Fusion cycle

- a) The reset stop button (if fitted on the control box) shall be checked to ensure it is in the correct mode and that the electrofusion control box input leads are connected to the generator.
- b) The control box output leads shall be connected to the fitting terminals and checked to ensure that they have been fully inserted.
- c) The fusion jointing time shall be entered into the control box timer (the preferred method is automatic recognition).
- d) The jointing time displayed on the control box shall be checked to ensure it matches that indicated on the fitting.

NOTE 1: If barcode readers are used for jointing time entry into the control box, it should be noted that some fitting designs use temperature compensation contained within the barcode. Temperature compensation changes the fusion times depending on ambient temperature and in these cases the fusion time stated on the fitting will not match that displayed on the control box. It is recommended that the installer checks with the fitting manufacturer before use.

- e) The start button on the control box shall be started and a check made that the heating cycle is proceeding as indicated by the display countdown.

NOTE 2: Under rare and extreme malfunction conditions, a small amount of molten PE material may escape from the joint or from the fusion indicators. Alternatively, sparks, or small splashes of molten metal may emit from the terminal connectors. Such occurrences are very rare, but operators should wear appropriate Personal Protective Equipment as identified in the risk assessment.

NOTE 3: Where molten material has escaped from the joint, this indicates either a malfunction of the electrofusion control box or excessive misalignment of

the pipe and fitting. This escape may lead to voids in the joint and the joint should be cut out and replaced.

6.1.6 Visual joint checks

- a) Once the fusion cycle has been completed, the operator shall check that the full fusion time has elapsed and that the control box displays no error warnings.
- b) The insertion marks on the pipe shall be checked to ensure excessive pipe movement has not occurred.
- c) The joint shall be retained in the clamps for the correct cooling time (stated on the fitting).
- d) The melt indicators on the fitting shall be checked to ensure they have risen. If there is no apparent movement of one or both the melt indicators, the joint shall be cut out and a new joint made.
- e) Signs of melt movement outside the confines of the fitting shall be checked visually. If melt has exuded beyond the ends of the fitting, the joint shall be cut out and new joint made.
- f) Under no circumstances shall an attempt be made to carry out a second fusion cycle on any fitting.

6.2 Saddles

6.2.1 Pre-jointing checks

- a) The pre-jointing checks shall be in accordance with 6.1.1 of this specification.
- b) Saddles may be fused onto PE pipes with a removable skin, once an appropriate area of the skin has been removed. The specific instructions of the manufacturer shall be followed.
- c) It is not permitted to join saddles to PE barrier pipes by electrofusion. Alternative solutions, such as mechanical ferrules shall be used, but such fittings shall be approved for use with the pipe in question.

6.2.2 Preparation – pipe surface

- a) Prior to scraping, the pipe surface over the general area on which the saddle is to be assembled shall be cleaned using clean disposable, lint-free material or a 'wet wipe'.
- b) The packaged fitting shall be placed over the required position on the main. The pipe surface to be welded shall be marked all round allowing a

10 mm clearance from the saddle base area and the area hatched using a suitable marker.

- c) The surface of the pipe over the full marked area shall be scraped using a suitable sharp tool to a depth of 0.2 mm to 0.4 mm. All swarf shall be removed but once prepared, the pipe surfaces shall never be touched.
- d) If surfaces are contaminated by dust or mud following scraping, then 'wet wipes' can be used to clean surfaces (see 6.1.3 of this specification).

6.2.3 Saddle jointing procedure

- a) The fitting shall be removed from its bag and carefully placed onto the prepared pipe surface. Neither the pipe nor fitting jointing faces shall be touched whilst assembling.
- b) The correct pre-set load shall be applied to the saddle fitting using the appropriate clamping method (seek manufacturer's advice if unsure).
- c) The fitting shall be connected to the control box and fused as 6.1.5.
- d) Once the fusion time has elapsed the clamp shall be retained on the fitting for the appropriate cooling time stated on the fitting.
- e) The main shall not be tapped with the integral cutter for at least 10 min. after completion of the cooling cycle and on successful completion of a visual inspection.
- f) A two-minute hydraulic pressure test at 1.5 times the nominal pressure rating of the pipe or fitting whichever is the lower shall be applied to the fused fitting prior to tapping.
- g) All joints shall be visually checked to ensure that there is no leakage whilst the pressure test is applied.

NOTE: It is strongly recommended that gloves and goggles be worn during the jointing process.

6.2.4 Visual saddle checks

- a) The visual checks shall be in accordance with 6.1.6 of this specification.

- b) If the saddle fails to complete the correct fusion cycle or fails a visual inspection, the tee shall be cut from its base as shown in Figure 4 and a new saddle joint made.

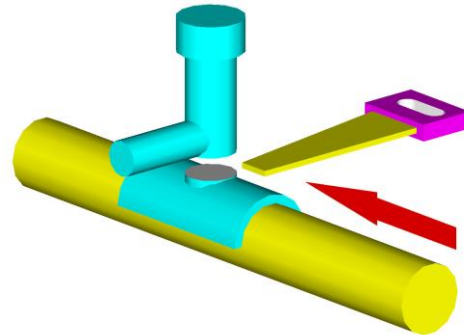

Figure 4 Removal of saddle joint

7. QUALITY ASSURANCE

7.1 Requirements

To claim compliance with this specification, installers shall operate a management control system for site fusion jointing practice preferably to BS EN ISO 9001.

7.2 Quality Control System

The installer shall ensure that fusion jointing procedures as well as servicing and maintenance of fusion jointing equipment are carried out in accordance with the requirements of this specification.

On each site where pipes and fittings are to be jointed in accordance with the requirements of this specification, a control systems shall be established to supervise work affecting quality.

The installer shall establish and maintain procedures to show evidence of analysing work practices, capturing jointing records, jointing practice, installer identification, quality records, service reports and customer complaints. Electronic records from the electrofusion control box data logging function, together with jointing quality evaluation, shall be recorded and delivered to the client with site records in a format that provides full traceability, identification and location of each fittings installed.

7.3 Materials controls

The client/installer (depending upon the specifying entity) shall ensure that all pipes and fittings conform to specified requirements given in the relevant parts of BS EN 12201.

The installer shall ensure that all fusion jointing equipment conform to the specified requirements given in BS ISO 12176-1 or BS ISO 12176-2, as applicable.

The installer shall establish and maintain appropriate procedures for handling and storage of pipe, fittings and fusion jointing equipment.

The installer shall ensure that pipes, fittings and fusion jointing equipment are not used until they have been inspected and confirmed as conforming to the requirements of this specification.

7.4 Inspection and Testing

At the commencement of each contract, the frequency and type of inspection by the installer shall be agreed with the client and documented. This shall include evaluation of site joints, both electrofusion and butt fusion (if appropriate), using criteria stated in Clause 8.

The installer shall establish and maintain written records of appropriate fusion jointing procedures, servicing and calibration details in accordance with this specification.

The installer shall establish and maintain procedures for collection, indexing, filing and storage of quality records for a minimum period of seven years after completion of the contract within which the work was undertaken or as otherwise specified by the client.

7.5 Maintenance, servicing and calibration of equipment

All equipment shall be well maintained and kept in a clean condition both in stores and at all times on site.

The equipment shall be serviced and calibrated by authorized agents in accordance with the manufacturer's recommendations.

Calibration shall be carried out in accordance with BS EN ISO 10012. Written records of appropriate servicing and calibration details shall be kept.

For butt fusion, particular attention shall be given to the heater plate, the hydraulic unit, the frame/clamp unit, trimming tool and the generator.

For electrofusion jointing, the control box and generator shall be checked in accordance with the manufacturer's recommendations.

Mechanical scrapers shall be checked regularly for their scraping efficiency.

Top loading tools shall also be calibrated to ensure correct forces are applied.

8. TESTING OF JOINTS – ASSESSMENT OF TOUGHNESS

8.1 General

It is a water industry requirement that no joint made by butt fusion or electrofusion shall ever fail in a brittle manner. The jointing procedures and quality requirements set out in this specification should ensure that this is met for joints made on both construction sites and in suppliers' factories.

To ensure that joints have met this requirement, it is recommended that the inspection and testing plan as defined in 7.4 shall include sampling and destructive testing of joints made under site conditions.

To ensure compliance to BS EN 12201 (all parts) is achieved, and to enable comparison of site based results with the manufacturer's reference tests to be made, the jointing test methods stated in BS EN 12201 (all parts) shall be used for the assessment of site made joints.

8.2 Assessment of butt fusion joints

Samples taken from butt fusion joints at all diameters and wall thicknesses shall be assessed in accordance with BS ISO 13953 Type A with the exception of pipes having a wall thickness of 25 mm or greater.

NOTE: The testing methodology in BS ISO 13953 Type A is known as the RST (reduced section tensile) test.

For pipe thicknesses of 25 mm or greater, the test geometry defined in BS ISO 13953 Type A shall be used with the following modification:

- Pipes shall be first cut in the dumbbell form in BS ISO 13953 Type A and shown in Appendix 1, figure A.1 of this specification.
- Dumbbells shall be cut into two or more 'layers' such that the thickness of one or more layer to be

tested is in the range 20 mm – 30 mm, see Figure 5.

- When cutting the sample, a fine toothed saw shall be used to minimize material removal from the joint to be assessed.
- Samples reduced in this manner shall be subject to tensile testing in accordance with BS ISO 13953 and shall exhibit the ductile failure mode to achieve a pass.

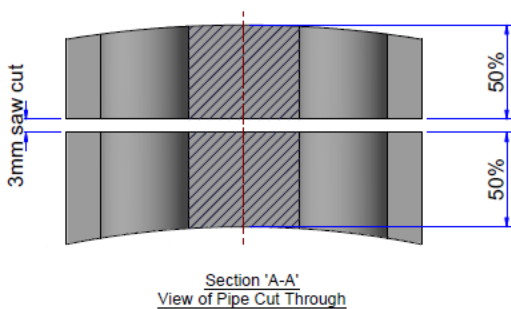
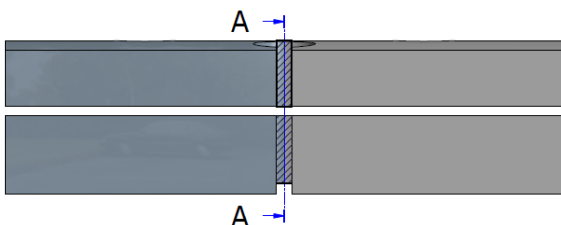
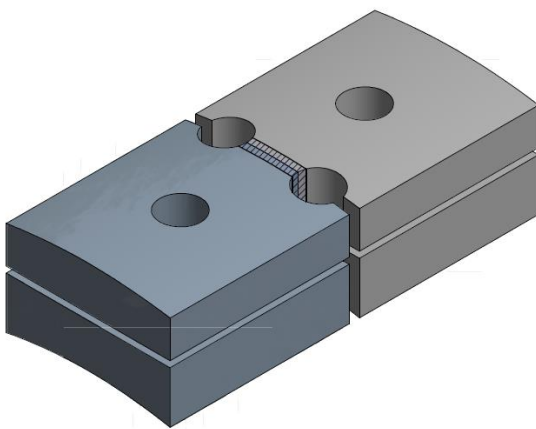

Figure 5 Preparation of samples from thick walled pipes

For all sizes, test joints shall be made when mobilising a new project site to verify the jointing equipment and competent operative can achieve the joint quality set out in this specification.

For sizes greater than or equal to 355 mm (PE, outside diameter), the contractor shall agree a sampling frequency for weld testing to be conducted during the contract.

Appendix A provides details on the interpretation of test samples using visual and analytical means. The appendix is provided as an informative guide to assist users of this specification. It does not constitute a formal requirement and should not be construed as such.

8.3 Assessment of electrofusion assemblies – socket fittings ≥ 90 mm

Electrofusion assemblies made using socket fittings, for example couplers, reducers, elbows, tees and caps, where the socket to be tested is 90mm or greater, shall be tested in accordance with ISO 13954.

NOTE: In the previous version of this specification, a test method was described to assess resistance of electrofusion fittings to contamination. The equipment to carry out this test is no longer available and a new method is under development.

8.4 Assessment of electrofusion assemblies – socket fittings < 90 mm

Electrofusion assemblies made using socket fittings, where the socket to be tested is less than 90mm, shall be tested in accordance with ISO 13955.

8.5 Assessment of electrofusion saddle assemblies

Electrofusion saddle assemblies, specifically the saddle base where it connects to the distribution main, shall be tested in accordance with BS ISO 13956.

9. REFERENCES

This specification makes reference to the latest edition (except where otherwise stated) of the following publications, including all addenda and revisions which should also be consulted.

British Standards

BS EN ISO 9001 Quality Management Systems – Requirements.

BS EN 12201-1 Plastics piping systems for water supply, and for drainage and sewerage under pressure. Polyethylene (PE). General.

BS EN 12201-2 Plastics piping systems for water supply, and for drainage and sewerage under pressure. Polyethylene (PE). Pipes.

BS EN 12201-3 Plastics piping systems for water supply, and for drainage and sewerage under pressure. Polyethylene (PE). Fittings.

BS EN 12201-5 Plastics piping systems for water supply, and for drainage and sewerage under pressure. Polyethylene (PE). Fitness for purpose of the system.

BS ISO 12176-1 Plastics pipes and fittings – Equipment for fusion jointing of polyethylene systems – Part 1 Butt fusion

BS ISO 12176-2 Plastics pipes and fittings – Equipment for fusion jointing of polyethylene systems – Part 2 Electrofusion

BS ISO 13953 PE pipes and fittings – determination of the tensile strength and failure mode of test pieces from a butt-fused joint.

BS ISO 13956 Plastics pipes and fittings – Decohesion test of PE saddle fusion joint interface by tear test.

BS EN ISO 10012 Measurement management systems. Requirements for measurement processes and measuring equipment.

International Standards

ISO 13954 Plastics pipes and fittings – Peel Decohesion test for PE electrofusion assemblies of nominal outside diameter greater than or equal to 90mm.

ISO 13955 Plastics pipes and fittings – Crushing Decohesion test for PE electrofusion assemblies.

Water Industry Specifications

WIS 4-32-19 Polyethylene pressure pipe systems with an aluminium barrier layer for potable water supply in contaminated land – size 25mm to 630mm.

APPENDIX A - INTERPRETATION OF BUTT FUSION JOINT SAMPLES

A.1.0 Basic description of the test method for butt fusion joints

The test method stipulated in BS ISO 13953 Type A (with appropriate test geometry modifications for pipe of wall thickness of 25 mm or greater) takes precedence in contracts and in any dispute. This informative annex has been included to retain experience gained by the UK Water Industry and provides an informative resource for users who wish to further analyse the butt fusion joint quality.

In the earlier versions of WIS 4-32-08 (Issues 1, 2 & 3), butt fusion joints were assessed using test pieces with the RST geometry illustrated in Figure A.1 below. Such test pieces were used irrespective of the pipe diameter or wall thickness.

The benefit of the RST test geometry specimen is that it forces failure to occur in the area where the joint has been made which does not occur for parallel-sided geometry specimens as given in BS ISO 13953 Type B unless the quality of the joint is particularly poor. This supports the industry position that joints should be assessed and shown not to fail in a brittle mode. The test though has relied upon a visual assessment of the failed surface to determine whether the joint is ductile or brittle, and round robin tests show significant variation in the interpretation of results. This is particularly problematic with test pieces made from pipe whose wall thickness is significantly greater than the width of the reduced section in the test geometry.

A.1.1 Selection of test shape, effect of geometry

The RST test geometry is specified in BS ISO 13953 Type A and is used for all pipe thicknesses up to 25 mm. This informative annex therefore focuses more on the options available for assessing test pieces taken from pipe of wall thickness of 25 mm or greater.

According to BS ISO 13953, for pipes having wall thickness greater than 25 mm, a long-waisted tensile piece is used but this is not recommended as explained in A1.0.

Where the informed user of this specification wishes to deliberately force failure at the joint interface for weld samples made from pipe of 25 mm or greater, then the RST test geometry (BS ISO 13953 Type A) can be used but an aspect ratio of 0.8 to 1.2 should be retained by taking slices through the pipe wall. This means that thickness is limited to a maximum of 30 mm and for thicker pipes, specimens of less than full wall thickness would need to be prepared.

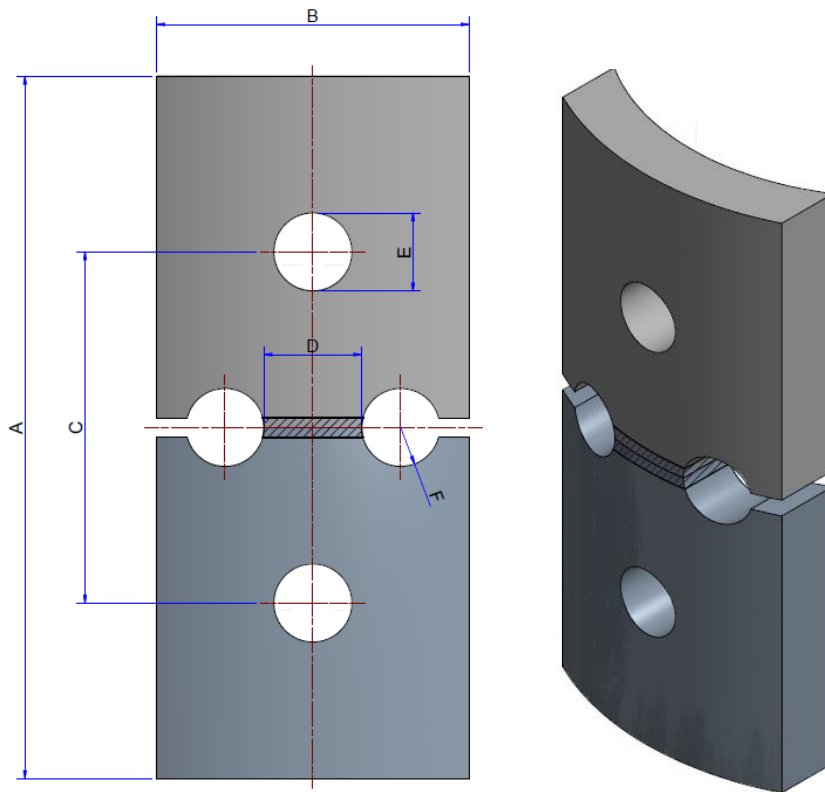

 Shaded Area is the Butt Weld Internally & Externally De-Beaded

Symbol	Description	Pipe Dia ≤ 160	Pipe Dia > 160
A	Overall Length (min.)	180	180
B	Width at Ends	60 ± 3	80 ± 3
C	Initial Distance Between Grips	90 ± 5	90 ± 5
D	Width of Narrow Portion	25 ± 1	25 ± 1
E	Diameter of Traction Holes	20 ± 5	20 ± 5
F	Radius	5 ± 0.5	10 ± 5

Figure A.1 Tensile test geometry (WIS methodology)

It is important to test both the inner and outer extremity of the joint once the bead is removed because any contamination is often pushed to these extremes and can prove to be the difference between a good and bad joint. When taking slices through the thickness of the pipe it is therefore important to leave these extremities intact. Where possible, it should be attempted to test both the inner and outer extremities for the specified number of specimens per joint, which may be achieved by testing inner/outer specimens from the same wall section or cutting neighbouring specimens to achieve the same goal.

For reference, aspect ratio is defined as the wall thickness divided by the width of the joint in the test geometry shown in Figure A.1. The use of a modified geometry wherein the aspect ratio of the test piece is less than 1.2 makes it easier to use visual methods to assess joint quality.

A.1.2 Visual interpretation of RST geometry test samples

Plate A.1 shows the classical failure mode expected when testing butt welds using the WIS sample

geometry, whilst Plate A.2 shows the modes deemed to be a failure.

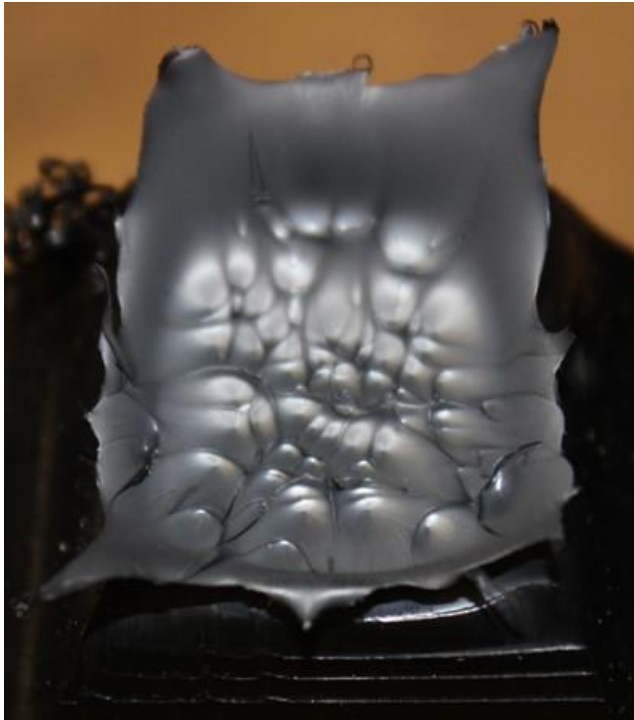

Plate A.1: Ductile mode failure

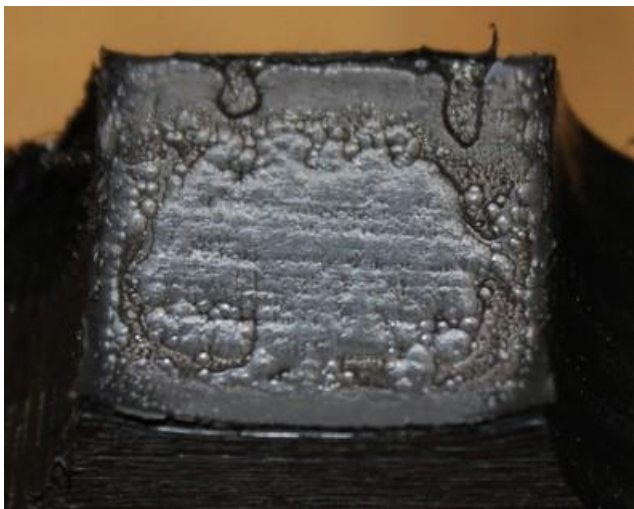

Plate A.2: Mixed mode failure

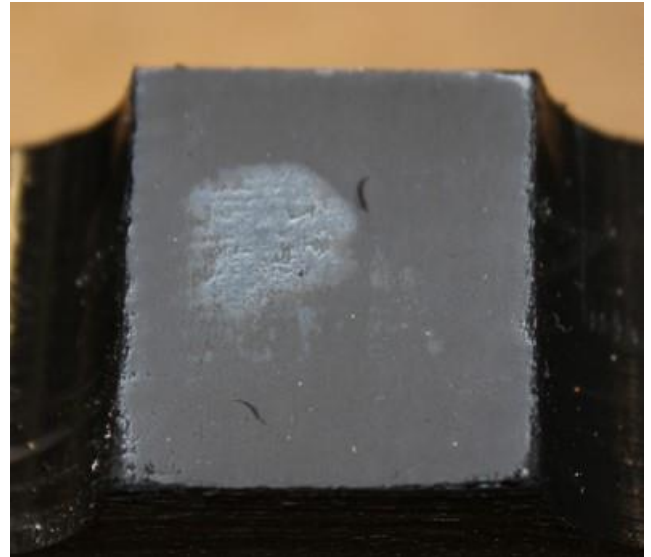

Plate A.3 Brittle mode failure

Experience has shown that testing of thick wall pipes can produce results which at first glance look like the pipe shown at the top of Plate A.2. This is misleading as acceptable ductile joints can from a distance look visually similar to an uninformed reader. The explanation for this lies in the failure mode for thick section test pieces. As the sample is elongated in the tensile testing machine, the outside edges of the sample begin to yield in a ductile manner but due to the larger cross-sectional area, the centre part of the sample experiences plan strain conditions which restrict the extension of the material. The surface in this areas may therefore appear less ductile than the same surfaces.

Attention is drawn to the fact that in all cases the failure is from the centre of the joint radiating outwards, and the surface of the joint exhibits gross drawing or wave forming of the surface of the material.

A.1.3 Analytical interpretation of WIS test samples

A preferred approach that removes the subjectivity of visual assessment is to make use of the ability of the tensile testing machine to record a load-extension chart. Figures A.2 and A.3 illustrate the broad means of assessing a ductile joint and a brittle joint using this approach.

Furthermore, numerical values may be obtained to compare joint performance by calculating the area under the force/extension curve, which may be related to energy to failure (kJ/m^2) by dividing by specimen geometry (width multiplied by thickness) and rationalising the units. Experience has shown that energy values above 300 kJ/m^2 are expected to be satisfactory, with those between 250 kJ/m^2 and 300 kJ/m^2 requiring reference to the fracture surface as before.

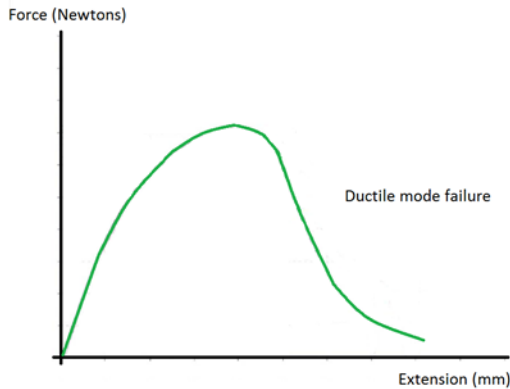

Figure A.2 Ductile failure

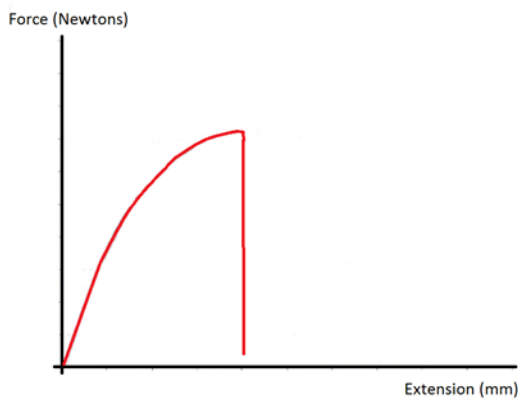

Figure A.3 Brittle failure

A.1.4 References for further reading

Beech S H et al; “Harmonisation of PE pipe butt fusion procedures and test methods”, PE100+ Association, Bucharest, 2008

Beech S H et al; “Harmonisation of polyethylene pipe butt fusion procedures and test methods”, PE100+ Association, Barcelona, 2012

Hill D et al; “Butt fusion welding of large diameter (thick walled) pipe”, Plastics Pipes XI, Munich 2001

Lowe D et al, “Optimisation of Butt Fusion Welding (and Testing) of Thick Walled PE100 Pipe”, Plastics Pipes XIII, Washington 2006.

Wilson K; “Verification of butt fusion welding quality in large diameter PE100 water pipes”, Plastic Pipes IX, Edinburgh 1995

APPENDIX B – RELATIONSHIP BETWEEN INTERFACE STRESS AND GAUGE PRESSURE

Within this specification, the Interface Stress for Bead Up, Fusion and Cooling is specified as being 0.15MPa for single pressure, (dropping to 0.025Mpa for Dual Pressure).

INTERFACE STRESS is the FORCE exerted over the AREA of the pipe ends.

To calculate the required FORCE on the pipe ends from the INTERFACE STRESS:

$$\text{Force (N)} = \text{Interface Stress (N/m}^2\text{)} \times \text{Pipe Cross Sectional Area (m}^2\text{)}$$

The interface stress in MPa needs to be converted to N/m² using a conversion factor of 10⁶ (i.e. 1 MPa = 10⁶ N/m²)

$$\text{Interface Stress (N/m}^2\text{)} = 0.15 \text{ (MPa)} \times 10^6 = 0.15 \times 10^6 \text{ N/m}^2$$

As an example, to produce an Interface Stress of 0.15 MPa on the pipe ends of an SDR 11 / 200 mm pipe, a force of approximately 1520 N (or 1.5 kN) is required.

In hydraulic powered butt fusion machines, the pump needs to generate a pressure on its cylinder that will produce a force on the pipe ends. This pressure is the GAUGE PRESSURE and is traditionally measured in bar (1 bar = 100,000 Pa = 0.1 MPa).

To calculate the required GAUGE PRESSURE from the FORCE required in the pipe ends:

$$\text{Gauge Pressure (N/m}^2\text{)} = \text{Force (N)} / \text{Cylinder Cross Sectional Area (m}^2\text{)}$$

So in the example, to produce a force of 1520 N using a butt fusion machine with a cylinder cross sectional area of 6 cm² (0.0006 m²), a gauge pressure of 2.5 x 10⁶ N/m² (2.5 MPa, 25 bar) is required.