WATER INDUSTRY INFORMATION & GUIDANCE NOTE

UK Water Industry

CODE OF PRACTICE: *IN SITU* RESIN LINING OF WATER MAINS

CONTENTS

1. INTRODUCTION
2. PROCESS SUMMARY
3. APPROVALS
4. *IN SITU* SPRAY-APPLIED RESIN LINING PROCESS

1. INTRODUCTION

The purpose of this Code of Practice is to supplement the Operational Requirements for *In Situ Resin Lining of Water Mains*⁽¹⁾. It is essentially a guidance document containing background information and recommendations for resin lining schemes.

Not all Operational Requirements are referenced in this Code but are fully set out in 'Operational Requirements: *In Situ Resin Lining of Water Mains*'⁽¹⁾, hereafter referred to as the 'OR'

The Operational Requirements (including all Appendices referenced from the Operational Requirements) are mandatory.

It is recommended that the Code of Practice forms the basis of the contractual requirements for *in situ* resin lining works, though clauses may be amended to suit individual client circumstances. However, tender documents should clearly indicate if any amendments have been made to the standard specification and what those amendments are.

1.1 Scope

This Code of Practice covers the requirements needed to provide protective coatings for pipelines constructed of iron, steel, asbestos cement, or concrete using resin materials approved for *in situ* lining of potable water mains. This currently includes two part epoxy resin and two part rapid setting polyurethane materials. Issues considered include:

- resin materials;
- approvals required;
- scheme preparation;
- pipeline cleaning;
- application of coating;
- curing;
- quality control procedures;
- disinfection; and
- rectification of lining defects.

Definitions (highlighted in ***bold italics***) are given in the Operational Requirements (OR 1.3).

2. PROCESS SUMMARY

2.1 Scope

For engineers and contractors who are not familiar with the cleaning and lining processes, this section provides a schematic summary of the methods.

This document has been prepared on behalf of the Water UK Standards Board. Technical queries should be addressed to the Standards Board c/o The Technical Secretary on E-mail: brian.spark@ntlworld.com IGN 4-02-02 replaces the DWI publication Code of Practice: *In situ* resin lining of water mains Version 2.2 30th October 2006. The latest version of this document can be downloaded from: <http://www.wis-ign.org>.

2.2 Cleaning

A number of cleaning techniques are suitable for the removal of debris and encrustation so as to prepare the main for lining. These include:

- Power Boring (diameter range 75mm to 250mm – see Figure 1);
- Drag Scraping (all diameters);
- Abrasive Pigging (diameter range 75mm to 300mm);
- Pressure Scraping (diameter \geq 300mm);
- Pressure Jetting (all diameters);
- “Whirlwind” or equivalent technique (75mm and above – see Appendix A).

Plunging can be used to remove residual corrosion debris and water from the pipe. Alternative cleaning methods are acceptable if they meet the requirements of OR 6.1 which specifies the quality of cleaning. Alternatives to those above should be checked with a nominated certifying body.

2.3 Preparation of Cleaned Mains

Prior to spray application of any resin material, the main shall be free from standing water. This is achieved by foam swabbing (using oversized clean swabs) and applies to all mains diameters of 75mm and above. Swabbing is used to remove residual corrosion debris and standing water from the pipeline.

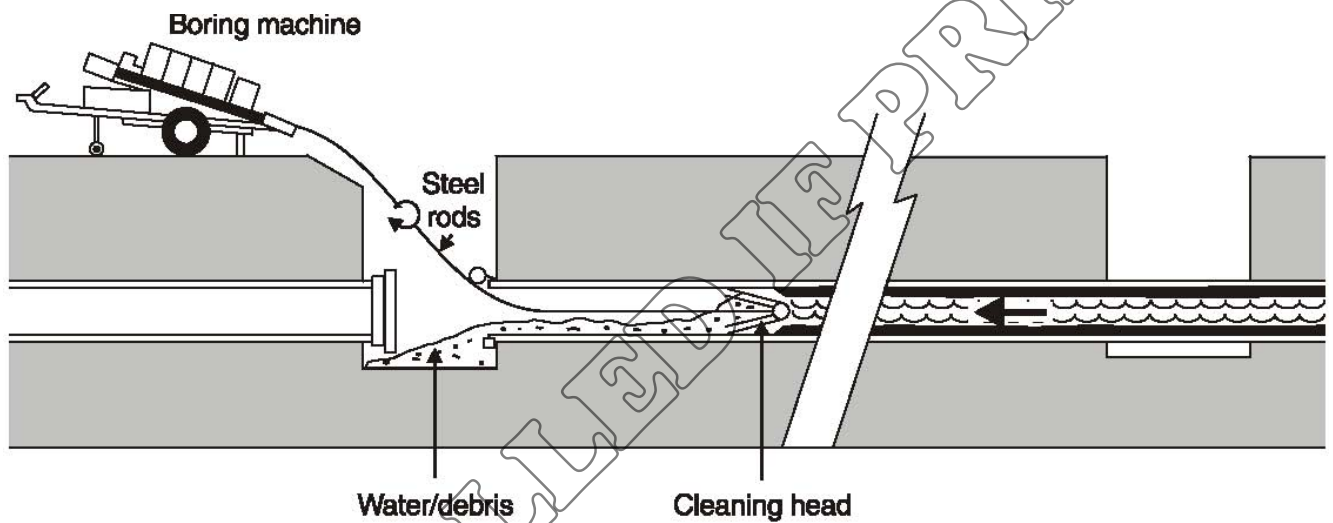

Figure 1 – Power Boring

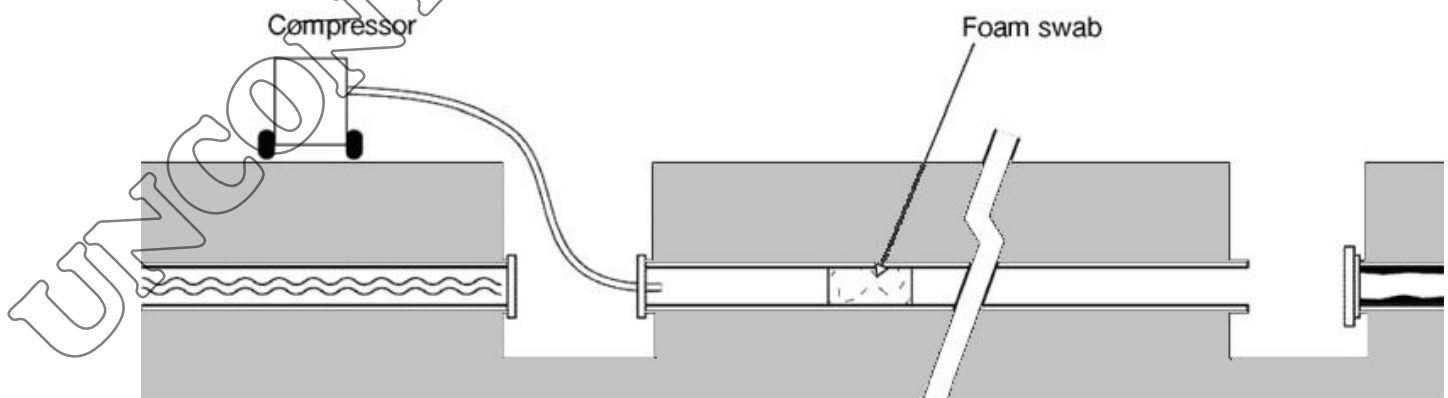

Figure 2 – Foam Swabbing

2.4 Pre Lining CCTV Inspection/Post Cure CCTV Inspection

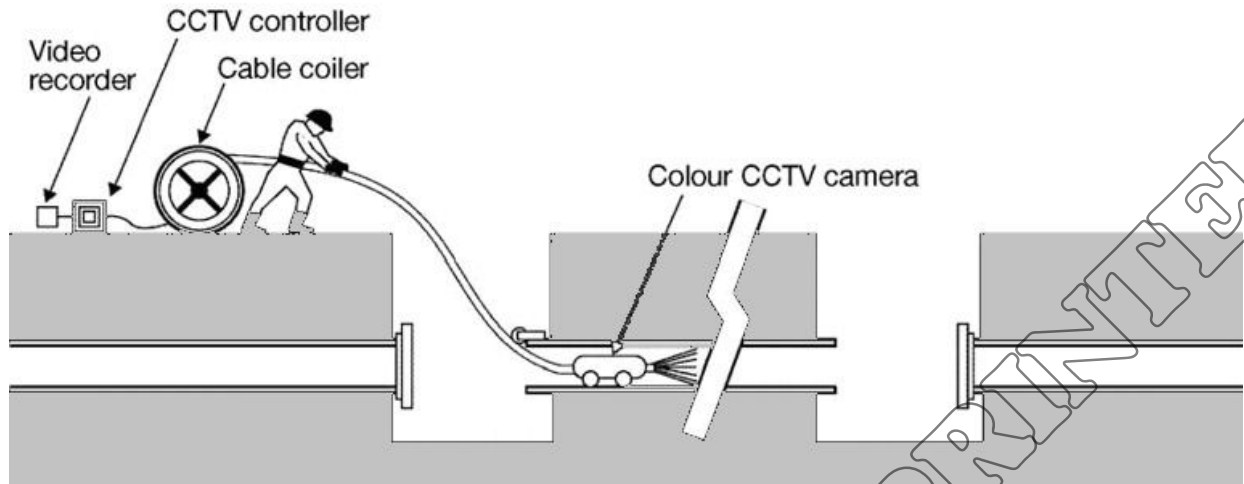

Figure 3 – CCTV inspection

2.5 Spray Lining

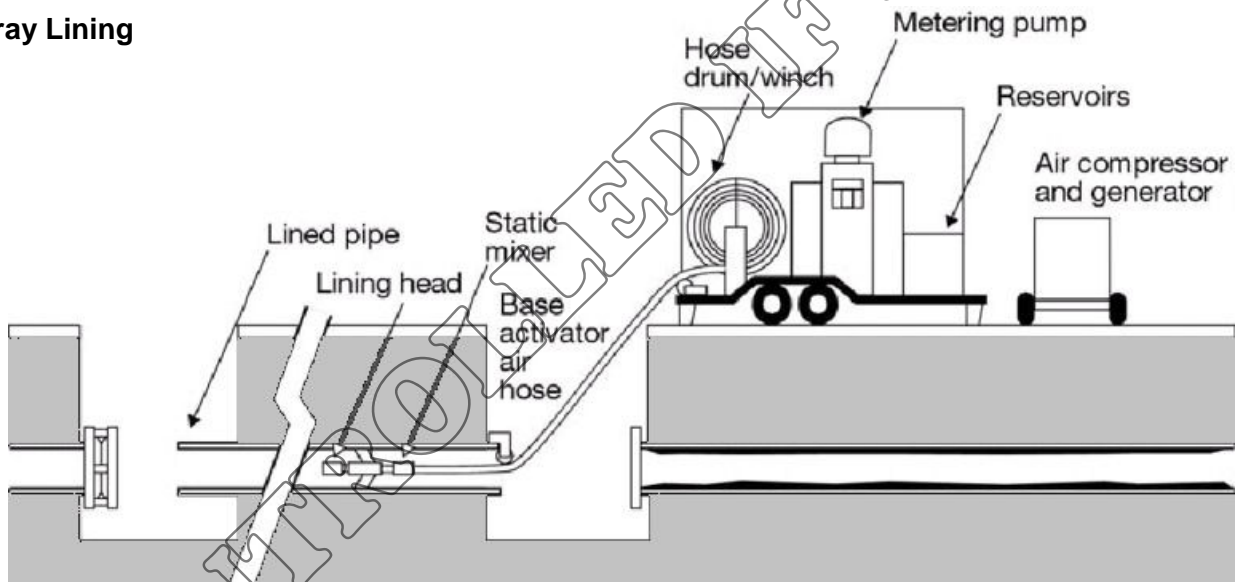

Figure 4 – Spray Lining

3. APPROVALS

3.1 Resin Materials (OR Section 2)

The resin materials used for *in situ* spray-applied resin lining of water mains are required to be moisture tolerant, solvent free systems. (OR 2.1)

The base and activator components shall be manufactured in two clearly distinguishable colours which, when correctly mixed, provide a third distinctive colour, thereby allowing for a visual evaluation of mix efficiency to be conducted. (OR 2.2).

Product specific information is provided in the manufacturer's Instructions for Use (IFU) document.

All approved *in situ* spray-applied resin materials (**Approved Coating Products**) are listed in the Authorities' List of Approved Products⁽²⁾, which is posted on the appropriate website: <http://www.dwi.gov.uk/31/approvedproducts/soslist.shtm> for the Drinking Water Inspectorate, <http://www.ehsni.gov.uk/environment/drinkWater/regulations.shtm#dwilist> for the Northern Ireland Drinking Water Inspectorate and <http://www.scotland.gov.uk/Publications/2007/03/08102144/0> for the Drinking Water Regulator for Scotland.

Resin manufacturers are required to possess (and provide on request) current documentary evidence that the materials have been tested and approved in accordance with the requirements for 'site applied materials'. This testing shall have been conducted using a curing regime that reflects typical site practice.

These approval requirements relate to the effect of the product on water quality and do not indicate fitness for purpose in terms of physical performance.

Under no circumstances shall **Approved Contractors** or Water Undertakers use resin materials that do not comply with these approval requirements

3.2 Lining Equipment (OR Section 3)

The approval process for an **Approved Coating Product** is based on the material formulation and its water quality performance, the method of

application as defined by the OR⁽¹⁾ and IFU documentation, and the equipment used in its application.

It is therefore essential that **Approved Coating Products** are applied using suitable pumping and monitoring equipment and that all ancillary equipment such as lining hoses, in-line mixers, and lining application heads are compatible with the resin material being applied.

3.2.1 Lining rig (OR 3.1 & 3.2)

The lining rig consists of separate storage containers for the components of the resin material, a heating system to correctly condition the resin components, a pumping system to supply the resin materials to the hoses and maintain the mix-ratio, a monitoring system, and a winch/drum upon which are mounted the hoses that convey the components to the application head.

Optimum pumping and mixing efficiency is obtained by careful regulation of the temperature of the resin components. Heating of these materials shall be in accordance with the manufacturer's instructions.

The lining rig shall therefore incorporate a heating system with controls to prevent overheating. Facilities to recirculate the resin components in the reservoirs through the lining hoses prior to lining are also required.

Dependent upon the resin material formulation, the storage reservoirs may require a nitrogen blanket to prevent atmospheric moisture pre-reacting with certain components in the material.

The output of the pump and the winch speed determine the coating thickness and the lining rig shall be designed to give control over these parameters.

It is recommended that the operation of the rig monitoring system be sequential so that lining cannot commence until key information has been collated by the operating system, including data input by the Rig Operator. Such a sequence should include warm up, weight check, with the input to the controller of three consecutive sets of data meeting the tolerance requirements, at intervals of a minimum of 3 minutes; and spin-up, with countdown of the spin up time between starting of the metering pump (in spin up mode) and starting

of the winch to commence lining, prior to the actual lining.

In addition to the specified requirements for the monitoring system (and print out) supplying the following information is considered good practice:

- umbilical temperature (base and activator resins);
- mix-ratio during spin-up.

Appendix C of the OR⁽¹⁾ details the standard assessment procedure for determining whether a spray-applied resin lining rig complies with the design and performance criteria required to meet the conditions of approval. This schedule may not be applicable to rigs that incorporate alternative monitoring technologies, assessed in accordance with the terms of Appendix F of the Operational Requirements.

Separate approvals are required for each combination of rig design and resin material.

Lining rigs shall be calibrated and audited according to the schedule and requirements set down in OR 3.3.

3.2.2 Lining hoses (OR 3.4)

The hoses shall have a suitable pressure rating for conveyance of the resin materials, and shall not be susceptible to any significant chemical attack from the materials.

Umbilicals shall contain separate lining hoses that have a suitable pressure rating for the conveyance of resin materials and are resistant to chemical attack from the resin components.

The umbilical shall contain a fully pressure-rated heating line that helps maintain the temperature of the resin components through the umbilical if this is required by the material manufacturers approved lining Instructions for Use (IFU). The umbilical should also contain reinforcement to reduce stretching and the whole hose bundle, including the airline, should be suitably sleeved.

Minor scuffs to the outer sheath of the umbilical can be repaired locally. In certain circumstances, seriously damaged heated umbilical hoses may be successfully shortened provided there has been no damage to the base, activator or heating water lines.

3.2.3 In-line mixer (OR 3.5)

The satisfactory mixing of the resin components is fundamental to the application of a coating that has optimum water quality performance and durability. The resin components are pumped separately through the lining hoses and are mixed immediately prior to the application head by an in-line mixer.

The manufacturer of the **Approved Coating Product** shall specify the types of in-line mixer that are suitable and have been approved for use with their material and include details of these in the IFU.

In-line mixers shall be marked indelibly so as to provide an audit trail that allows the **Utility Representative** or independent Auditor to confirm that the in-line mixer being used has been approved for use with the **Approved Coating Product** being applied.

3.2.4 Lining application head (OR 3.6)

The use of *in situ* spray-applied resin materials requires an application (spinner) head design that minimises the risk of blockage.

The design of the head will depend on the viscosity and setting properties of the material being applied. The contractor must ensure that the application head employed is designed for rapid material transfer and with a self 'cleaning' cone that applies a coating of specified thickness with minimal riddling and pin holing.

Irrespective of the setting properties of the resin material being used, the application head shall be designed to centralise the head in the pipe and shall not have protruding attachments that could catch on dropped joints or protruding ferrules, thereby causing lining misses (see Section CP 4.19.3).

In addition, the application head shall incorporate rear venting air exhaust ports to minimise the occurrence of linings contaminated with blown dust and debris (see Section CP 4.19.10).

3.3 Approved Lining Contractors (OR Section 5)

Resin linings shall only be applied by **Approved Contractors**. Direct employees of the **Approved Contractor** shall undertake the following quality-critical operations:

- lining rig operation, including warm up and safety checks;
- storage and handling of resin materials and cleaning fluids;
- quality checks on cleaning efficiency;
- weight checks;
- temperature checks on base and activator prior to lining;
- spin-up procedures;
- lining procedures;
- pre cure/post cure inspections;
- rectification of lining faults;
- recording of all quality critical data.

Sub-contract labour may only be used for ancillary site work, and not for any aspect of the lining that may affect the quality of the applied coating.

Subcontracting, by an **Approved Contractor** to unapproved contractors (including subsidiary companies or franchises etc.) constitutes a breach of the conditions of approval

4. IN SITU SPRAY-APPLIED RESIN LINING PROCESS

4.1 General

This section of the document considers the procedures necessary for the successful spray application of resin materials to potable water mains.

All the procedures included in this section shall be included (explicitly or by reference) in the **Approved Contractor's** Quality Management System and the contract documentation of the Water Undertaker.

Approved Contractors shall implement schemes to required standards and as the situation demands, for:

- i) customer care (e.g. notification, site information boards);
- ii) street works;
- iii) provision of alternative supplies;
- iv) site cleanliness;

v) risk management associated with the potable water system (e.g. upstream contamination prevention, adherence to valve operations requirements, site contamination, disinfection, CDM and health and safety issues, temporary pipe work, etc.).

Site practice shall not compromise the quality and cleanliness of the lining process.

4.2 Preparatory Work

In common with other renovation techniques, satisfactory and suitable preparatory work is essential for the successful completion of an improvement scheme. A range of activities shall be addressed, and the following list is provided for guidance (it is however, not exhaustive).

- Contract document preparation.
- Detailed investigation for improvement justification and generic technique selection.
- System preparation including site investigation and enabling works.
- Customer care planning.
- Consideration of waste/effluent disposal.
- Availability of water.
- Risk assessments.
- CDM/Health and Safety requirements.
- Maintenance of supplies.
- Arrangements for sensitive customers/consumers.
- Bypass arrangements.
- Discussions with other Utilities, Highways Authorities and The Fire Service.
- Environmental assessments.
- Site access.
- Mains isolation.
- Location and closure of all stop taps.
- Provision of alternative water supplies.
- Provision of an in-line chlorinator to maintain background free chlorine residuals when required.

4.3 Fittings

Within normal distribution systems there is a wide range of fittings whose performance may be adversely affected if cleaned and lined incorrectly. Generally therefore all bends with an angle of greater than $22\frac{1}{2}^{\circ}$, tapers, valves, hydrants, washouts, swabbing chambers, tee pieces and

legged-off fittings should be replaced as part of the contract.

Air valves, flow meters and pressure reducing valves should be removed and replaced after lining. Only ferrules should normally be lined *in situ*, except in the case of deep (protruding) ferrules, which should be replaced. It is recommended not to line through valves *in situ* and these should be removed as part of the remedial process.

4.4 Make-Up Pieces

It is common practice for cut-outs for access to be replaced by ductile iron pipe previously lined with spray-applied resin material or with new ductile iron or polyvinyl chloride (PVC-O, PVC-A or PVC-U) pipes and fittings, as specified by the Water Undertaker. Polyethylene may be used as long as specifically designed couplings are utilised (the pipe can creep and subsequently leak if standard couplings are used).

4.5 Resin Material Handling

The storage, handling and temperature requirements of resin materials are important and the material manufacturer's instructions shall always be followed. Incorrect storage and the uncontrolled use of ancillary heating devices present the greatest risk to overheating stored product. Storage conditions shall therefore be closely monitored.

Any resin material stored outside the resin material manufacturer's specified temperature range shall be quarantined and disposed of appropriately.

The **Approved Contractor** should therefore ensure that the resin components are stored in a suitable, temperature controlled, secure environment and are used in date order. In addition, material batch numbers shall be recorded on the quality control documentation so that material production can be related to applied coatings.

4.6 Site checks

The **Utility Representative** shall conduct site checks on the lining equipment and the materials supplied (including resin material storage facilities).

At the start of the contract, the **Utility Representative** shall confirm with the **Approved Contractor** the suitability of the materials and

lining equipment. This shall be reconfirmed regularly and the **Utility Representative** shall be made aware of any changes to lining equipment or materials.

4.7 Access

After pre-lining works have been properly completed the mains should be isolated by the operation of appropriate valves. Customers' stop taps shall then be closed to prevent backflow.

Excavations shall be of a suitable size to gain safe access to the water main and shall meet the following criteria:

- i) be located to allow clear access for all cleaning and lining operations to take place;
- ii) the depth excavated beneath the pipe invert shall be a minimum of 150mm and sufficient to allow secure end caps to be fitted and prevent contamination of the pipe with excavation and other spoil;
- iii) a suitably sized sump shall be excavated to aid removal of water from the excavation and prevent the water from entering the pipe; and
- iv) suitable sized pumps and further disposal methods shall be used to remove water from the excavation and keep the water level below the pipe invert at all times.

The **Approved Contractor** shall comply with the current provisions for signing and protection of excavations.

Once excavated, a section of pipe of sufficient length to allow the renovation equipment to be inserted and removed should be cut from the main.

The pipe shall be cut such that a secure end cap or other fitting can be properly used. The pipe cutting equipment shall be suitable for the material and diameter of the pipe to be cut. Suitable safe working procedures shall be adopted.

4.7.1 Contamination of main by sewage

In the event of fracture of a sewer or drain during the course of the relining work such that foul water gains access to the excavation or pipes, rigorous isolation and disinfection procedures shall be

carried out in accordance with the principles of Technical Guidance Note No 3 Distribution System (Repaired Mains) contained in Principles of Water Supply Hygiene and Technical Guidance Notes¹⁽³⁾

The main shall not be returned to service until two consecutive satisfactory bacteriological results have been obtained.

4.8 Cleaning

A number of cleaning techniques are considered suitable for the preparation of pipelines for *in situ* spray-applied resin linings. These include power boring, drag scraping, abrasive pigging, pressure scraping, pressure jetting and the "Whirlwind" or equivalent technique. The diameter ranges over which these methods are effective are given in CP Section 2 above. Other methods can be used provided they comply with the performance requirements of OR 6.1.

Generally, power boring is the chosen method for mains of diameters up to 250mm with mains of greater diameter usually being drag scraped. The choice of cleaning method is at the discretion of the Water Undertaker and/or the **Approved Contractor** as defined in the Contract Specification.

The quality of cleaning is paramount if coatings are to be applied successfully. The cleaning method employed shall leave the bore of the pipe free of tuberculation, deposits and loose or deteriorated remains of original coatings. Graphitisation may or may not remain depending on the cleaning process used.

The following shall be incorporated into the cleaning process:

- i) cleaning water shall be passed through suitable apparatus to remove coarse debris;
- ii) any flow of water used for flushing the mains during the cleaning process shall be controlled to ensure it is sufficient to remove the debris but does not overload any pump and flood the excavation;
- iii) all water and debris shall be suitably disposed of in compliance with the requirements of the Environment Agency (or equivalent organisation) and any relevant sewerage undertaking requirements;

iv) for mains that are drag scraped, all debris shall be removed by plunging before foam swabbing;

v) the main shall be further prepared by passing oversized foam swabs along the main; and

vi) any cables, rods or wires used during the cleaning process shall not be allowed to come in direct contact with the excavation edge or cut pipe edge.

As noted above, residual water and debris shall be removed prior to lining by plunging and swabbing. The continuing presence of substantial amounts of debris and/or water suggests inadequate cleaning and/or leaking valves and these faults shall be investigated and remedied.

It is to be noted that the degree of surface preparation for larger pipe diameters is of greater importance due to reduced hoop strength of the cured lining.

4.8.1 Return to service after cleaning

Cleaned mains shall not normally be returned to service without lining. This is to avoid discoloured water, increased microbiological activity and increases in PAH levels that arise from exposure of the freshly cleaned surface to the water supply.

Under exceptional emergency circumstances and only with written permission of the **Utility Representative**, it may be allowed to return cleaned mains to service overnight before lining. In such cases the main shall be chlorinated in accordance with the Water Undertaker's Disinfection Code of Practice¹ and then flushed before opening stop valves. Customers shall be warned to run their taps to remove debris that may have collected in the ferrule and also that the water being supplied is not suitable for drinking or cooking. Alternative supplies of potable water shall be provided.

¹ Each Water Undertaker publishes a Disinfection Code of Practice which is aligned to Water UK's Principles of Water Supply Hygiene and Technical Guidance Notes⁽³⁾. This should also be consulted.

Whilst the main awaits lining, a flow shall be imposed on dead ends sufficient to ensure the residence time does not exceed 1 hour. (On a 100 mm diameter main of 100m length, a flow to waste of 13 lmin⁻¹ would be sufficient to do this). Due consideration shall be given to the possibility of causing pollution through discharging water containing PAHs, iron and manganese into a drain leading to a stream or watercourse. Appropriate action shall be taken, as determined by the **Utility Representative**.

4.9 CCTV Inspection (OR 6.2)

A colour CCTV inspection of the whole main with video or digital recording shall be carried out to check the quality of the cleaning and highlight any potential problems such as:

- passing or leaking valves and ferrules;
- leaking stop taps;
- dropped joints;
- lead fish or other restrictions;
- protruding ferrules;
- structural failures; and
- standing water.

Any locations where problems might be expected (e.g. ferrule connections, valves) should be inspected with particular care.

All CCTV equipment shall comply with the minimum specification given in the Operational Requirements (OR 3.7). In addition, equipment with a self-righting image is now available and its use is recommended.

The recording of the CCTV inspection shall show the condition of the main ready for lining and not an intermediate stage of cleaning. Hence, if cleaning faults are observed during the pre-lining CCTV inspection, the fault shall be rectified and the main then re-inspected. It is important when digital recordings are made that the **Approved Contractor** ensures that the disk is formatted correctly and stored in a suitable container to protect against subsequent damage.

Where the **Utility Representative** is unavailable, the decision to line the main may be made by the **Approved Contractor** but any cleaning defects that are subsequently identified by the **Utility Representative** should be rectified by the **Approved Contractor**.

4.10 Proving

It is important to ensure that there is free passage for the lining application head, which can be accomplished by passing a suitably sized 'prover' through the cleaned pipe length.

CCTV inspection often allows gross restrictions in the pipe to be identified, so explicit proving of the main may not be considered necessary. However, it should be noted that small changes in diameter associated with some repairs might not be identified during CCTV inspection, and these can result in lining problems. Use of a prover is therefore considered 'best practice'.

4.11 Weight Checks (OR 6.4)

Weight checks of the resin components shall be carried out to ensure the material output is within the resin manufacturer's specification. Such checks shall be reported on the Resin Lining Record (RLR) and shall conform to the following:

- i) be conducted prior to every lining with the rig fully operational in long circulation mode; that is, circulating through the entire length of the hoses;
- ii) resin material shall be collected at the anticipated flow rate for the lining in appropriately sized containers;
- iii) a minimum of 200g of base component shall be collected for each weight check;
- iv) a minimum of 3 minutes shall elapse between each weight check;
- v) before lining can commence, 3 consecutive weight checks shall be within $\pm 5\%$ (by weight of activator) of the resin manufacturer's specified mix-ratio, calculated as $100:(\text{weight of activator}/\text{weight of base} \times 100)$;
- vi) the third weight check shall be carried out immediately before the hoses are inserted into the main to be lined; the time of this weight check shall be recorded on the Resin Lining Record; and
- vii) scales used to weigh the samples shall record to ± 1 gram, shall be calibrated at a maximum of 6 monthly intervals, and shall be accurate to $\pm 1\%$ FSD.
- viii) if unheated lining hoses are used, the time between the final weight check and the start of lining application shall not exceed

30 minutes. If heated umbilical lining hoses are used, the time between the final weight check and the start of lining application shall not exceed one hour. If these times are exceeded, the hoses shall be withdrawn, the resin materials recirculated and the weight checks repeated.

4.12 Application of Coating (OR 6.5 to OR 6.10)

Storage reservoirs shall be filled prior to operation and the resin batch numbers recorded on the site paperwork. Tank filling shall be conducted with care to avoid moisture ingress into the resin system components.

The base and activator components shall be heated in the rig to within the range specified by the resin manufacturer.

Prior to lining, the **Approved Contractor** shall demonstrate to the **Utility Representative** the functioning of the pumping and monitoring systems by:

- demonstrating that the flow metering and pressure monitoring units are functioning, including checking that warning devices and alarm systems are operable;
- demonstrating that the pumping and flow metering units are functioning correctly by conducting defined weight checks on the proportion of base and activator delivered.

Once the lining rig is fully prepared and correctly heated, the temperature of the base and activator shall be recorded on the Resin Lining Record.

The hoses can then be winched into the main using a suitable clean cable. The hoses are drawn to and clear of the furthest access hole at which point the application head and in-line mixer unit are attached (OR 6.5).

Before lining commences and material components are pumped to the application head, the **Approved Contractor** shall check the head for malfunction. If functioning satisfactorily, the pumps are activated and mixed material is thereby delivered to the application head.

Since the base and activator are generally of different viscosities, resin material shall be pumped through the application head to waste until correct

stabilisation of the lining rig and satisfactory proportioning of the material has been achieved at the spinner head. The spin-up time varies according to the resin material used, the design of the lining machinery, and ambient temperatures (OR 6.6).

Under no circumstances can lining commence if any faults are identified during pre-lining checks or any doubt remains as to the correct material proportioning at the spinner head.

If the time between the final weight check and the start of lining exceeds 1 hour for a heated umbilical and 30 minutes for an unheated umbilical, the hoses shall be withdrawn and the resin materials re-circulated.

The actual spin-up time shall be recorded on the Resin Lining Record, or on the lining rig print out.

Once the **Approved Contractor** and/or **Utility Representative** are satisfied that the minimum spin-up time has elapsed, resin material consistency at the application head is acceptable, and the mix-ratio is within the required $\pm 5\%$ tolerance band, the lining can commence by withdrawing the hoses at a controlled rate.

The winch speed shall be controlled so that a lining of the specified minimum thickness is achieved at the material flow rates delivered by the rig pumping system.

4.12.1 Addition of resin material during lining (OR 6.3)

Approved Contractors shall ensure that wherever possible the reservoirs contain sufficient resin material for the lining.

Should it be necessary to add material while lining is proceeding, it shall be pre-conditioned to within the resin manufacturer's specified temperature range, so that it is the same temperature as the resin components in the reservoirs, to within approximately $\pm 3^{\circ}\text{C}$.

4.12.2 Monitoring of lining (OR 6.8)

The **Approved Contractor** shall monitor the performance of the lining rig throughout the lining. It is also considered good practice to monitor the sound of the application head; change in its sound can give an early indication of problems.

If the **Utility Representative** or the **Approved Contractor** suspects a fault with the equipment or the coating, the process shall be aborted and all lining equipment removed from the main.

After curing a suspected faulty lining for the period specified by the resin manufacturer in the IFU, the lining shall be rectified in accordance with OR 6.12 and with CP 4.18.

4.12.3 Dip cards

Under normal lining conditions, at least one dip card is taken immediately before commencement and a further dip card on completion.

The dip cards should be cured and can be retained as a permanent record.

4.13 Assessment of Lining Printout

Immediately after completion of the lining, the **Approved Contractor** shall review the lining printout to ensure compliance with WIS 4-02-01.

The **Utility Representative** shall review the lining printout within 24 hours of the completion of lining.

4.13.1 Assessment of mix-ratio criterion (OR 6.8)

For a lining to be considered acceptable 95% of the mix-ratios shall be within $\pm 5\%$ of the resin manufacturer's specified mix-ratio and 100% shall be within $\pm 10\%$.

Immediately following the lining, the lining printout shall be reviewed by the **Approved Contractor** (and/or **Utility Representative** if he/she is immediately available) to determine if this criterion has been met. If this criterion is not met a non-conformance record shall be filled out. The lining rig should be put into re-circulation mode and weight checked. These results shall be recorded on the Resin Lining Record. If the weight checks demonstrate a mix-ratio fault, the lining shall not be returned to service until rectification in accordance with OR 6.12 and CP 4.19 has been conducted.

If the weight checks are satisfactory, however, and given that mix-ratio faults can be indicative of flow meter and/or signal processing problems, rather than mix-ratio errors, the response should be in proportion to the risk.

If there is any additional evidence of mix-ratio fault (from CCTV inspection and/or pipe samples) then

appropriate measures shall be taken (i.e. relay contaminated pipe lengths in accordance with OR 6.12). However, if the non-conformity is only marginal (for example, the printout shows that the lining is only just outside the 95% criterion) and there is no evidence of poor cure/mixing, rectification may not be necessary.

The **Utility Representative** is the final arbiter of whether there is a potential risk to water quality and whether rectification is required.

4.13.2 Assessment of coating thickness criterion (OR 6.9)

The minimum coating thickness for resin linings is 1mm throughout the lining. However, there are signal-processing issues associated with the encoders used to infer coating thickness, as well as process variations that affect coating thickness estimates. To reflect these issues, unless otherwise specified in the procurement contract, a lining is deemed acceptable if 95% of the coating thicknesses recorded on the printout are not less than 1.00mm and 100% are not less than 0.90mm.

Similarly for any other thickness specified by the client the lining is deemed acceptable if 95% of the coating thicknesses measured by the monitoring system are not less than the specified thickness and 100% are not less than (0.9 x specified thickness).

If this criterion has not been met, a non-conformance record shall be filled out and appropriate actions taken.

If the printout indicates a thin coating, a sample shall be taken. Over-lining will be required if the coating is considered too thin. However, the response should again be in proportion to the risk. If the non-conformity is only marginal (for example, the printout shows that the coating is only just outside the 95% criterion), rectification may not always be necessary.

The **Utility Representative** is the final arbiter of whether there is a potential risk to longevity of the coating and whether rectification is required.

4.14 Curing (OR 6.10)

The cure period shall commence only when the lining head is removed.

The cure period specified in the individual manufacturer's IFU document will have been used as the basis of the approval of the resin material and under no circumstances can this period be reduced before return to service.

The use of end caps during curing is essential for resin materials that cure over night to prevent contamination of the lining and, in particular, the ingress of trench water.

For materials that set more rapidly, the use of end caps during curing is not absolutely necessary as long as lining operatives remain at each open pipe-end throughout the curing period. However, open pipe-ends shall be capped off if this is not the case.

4.14.1 Application temperature (OR 6.7)

Experience has shown that the minimum pipe wall temperature for application and cure is 3°C.

The pipe wall temperature is taken as the temperature of the water sampled through the nearest upstream hydrant of the main to be renovated. This should be conducted immediately before the main is isolated for cleaning and lining. Lining shall not be undertaken if this temperature is below 3°C.

This assessment shall be conducted if the ambient air temperature is (or is likely to be) below 5°C.

The **Approved Contractor** shall record the temperature of the water sample on the Resin Lining Record sheet.

4.15 Post-Cure Inspections (OR 6.11)

After completion of the cure period, a preliminary inspection of the pipe ends shall be undertaken to determine the coating hardness (degree of cure).

The **Approved Contractor** or **Utility Representative** shall inspect and record the quality of the lining at both pipe ends. During the inspection, the coating shall be checked physically; if the application were correct in terms of mix-ratio, all pipe ends would appear identical in terms of cure and hardness.

Once sufficiently hard to withstand the passage of a camera and in accordance with the IFU, the quality of the applied coating along its entire length shall be determined by colour CCTV inspection. Inspections of this nature allow for the evaluation of cure, proportioning and mixing, and for the assessment of any lining faults.

Site hygiene is important at this stage to avoid contamination of the pipe interior. CCTV equipment including cables shall therefore be clean on insertion. It is good practice to disinfect CCTV equipment and cables with 1000 mg/l free chlorine upon insertion to the main.

The speed of travel of the camera shall allow the survey to be carried out effectively and the whole pipe diameter to be inspected.

To avoid a potential need for re-inspection due to faulty recordings, it is good practice for the CCTV lining record to be checked before the CCTV mobile unit leaves the site.

Under no circumstances shall a main exhibiting lack of cure, mixing, or proportioning be returned to service until it has been rectified to the *Utility Representative's* satisfaction.

Any apparent water damage faults shall be immediately brought to the attention of the *Utility Representative*.

4.16 Pipe Sampling (OR 6.14)

The lining print out gives the nominal coating thickness, calculated from the pipe diameter and lining variables (pumping rate and winch speed). The actual thickness applied to the pipe is determined through pipe sampling.

When requested, **Approved Contractors** shall take pipe samples at an agreed point in the lined section of main but avoiding pipe ends at lining entry and exit points.

For pipe diameters up to 250mm diameter it is recommended that a pipe sample of 300mm in length be taken on average for every 500m lined. The frequency of pipe samples from pipes of diameter greater than 250mm would be at the discretion of the Water Undertaker though it is recommended to be at least 1 per 2km.

Pipe samples shall be removed by a method suitable to the pipe materials. For iron, these include pipe crackers for 3 and 4 inch pipes, hinged pipe cutters for 3 to 12 inch pipes, rotary pipe cutters for 6 to 40 inch pipes and compressed-air driven power cutters (not angle grinders) for 6 to 48 inch pipes.

Disc cutters should be avoided as they can cause damage to the coating by heat transfer and are not recommended for use in excavations.

Coating thickness shall be measured on both cut faces of the sample at the four clock positions of 3, 6, 9 and 12.

These coating thickness measurements can be made with a micrometer or more simply with a proprietary thickness gauge, which is capable of unambiguous cured coating thickness assessment. All measurements shall be recorded on the Pipe Sample Quality Record sheet.

In addition to thickness measurements, the pipe samples shall be examined for other lining faults with rectification in accordance with Section CP 4.19.

4.17 Disinfection (OR 6.13)

The IFU may state a disinfection procedure, including maximum levels for disinfection, if these are stated they must be followed.

The main shall be pieced-up using suitable couplings that have been disinfected in 1000 mg/l free chlorine. The couplings shall be protected both externally, using for example protective mastic and tape or proprietary coatings, and internally by the use of a suitable approved coating⁽²⁾.

The main shall be disinfected in accordance with the principles of Technical Guidance Note No 4 Distribution System (Renovated Mains) contained in Principles of Water Supply Hygiene and Technical Guidance Notes¹⁽³⁾.

In general, a quantity of approved disinfectant should be introduced into the main sufficient to yield a free chlorine concentration of 50mg/l⁻¹ for a contact time of at least 30 minutes. During this period customers' stop taps should remain closed.

In practice, the use of calcium hypochlorite (powder or tablet) introduced into the make-up pipe or sodium hypochlorite dosed, for example, via a ferrule connection inserted in the make-up pipe have proved the most convenient methods of chlorination.

The use of swab chlorination is not considered to be good practice because the velocity of the swab through the main cannot guarantee that the chlorine solution will be evenly distributed over the entire surface of the lined pipe.

The main should be charged with water by operation of an upstream valve. In all cases the main shall be charged in the direction of flow and when fully charged the joints of make-up pieces should be checked for leakage while maintaining the static mains pressure.

After disinfection the main shall be flushed for the period stated in the manufacturers IFU, or if no period is stated then for a period of 1 hour at 0.5 ms⁻¹. The flow of water required for various pipe diameters when flushing at this velocity is given in Table 1. It should be checked that chlorine concentrations have returned to background concentrations.

¹ Each Water Undertaker publishes a Disinfection Code of Practice which is aligned to Water UK's Principles of Water Supply Hygiene and Technical Guidance Notes⁽³⁾. This should also be consulted.

Table 1 Flushing rates for different diameter pipes to give 0.5ms⁻¹ velocity

Diameter (mm)	Flow rate (ls ⁻¹)
75	2
100	4
125	6
150	9

If the velocity cannot be achieved then the flushing shall continue for 1 hour at the maximum rate available.

Due care and attention shall be given to the disposal of water used in disinfection, which shall be rendered safe before discharge to the environment.

Once flushing is complete and chlorine residual measurements have returned to background level then customers' stop taps may be opened. On return to service a water sample shall be taken for bacteriological examination.

Precautions may be required to ensure there is no risk of overnight stagnation during the first night in service. A low flow of water through the main shall therefore be established at dead-ends, sufficient to give a residence time of not more than 1 hour for the first 24 hours in service. In practice for a 100mm diameter main of 100m length, this amounts to a flow of about 13 lmin⁻¹. This is especially important if the relined main supplies a dead end (defined as a short length of main, generally 200m or less, terminating in a wash-out).

It is to be noted that temporary dead-ends are often produced as the lining is applied to a main section by section. Consequently, there is a general requirement for imposing a low flow to reduce the risk of stagnation.

4.18 Spray disinfection

4.18.1 With the agreement of the **Utility Representative** the following process may be adopted as an alternative method for the disinfection of the main.

4.18.2 The Contractor must ensure that all customers' stop taps remain closed during the disinfection process.

4.18.3 All surfaces of pipes and fittings such as stop taps, ferrules and other equipment likely to come into contact with potable water should be wetted by spraying with or immersed in a solution containing 1000mg/litre free chlorine prior to installation.

4.18.4 After satisfactory completion of lining and CCTV survey, disinfection shall be carried out by spraying with a solution containing 1000mg/litre of free chlorine. The spray head shall be drawn through the pipe ensuring that all surfaces of the pipe are adequately wetted. The volume of chlorinated water to be applied to the pipe shall be sufficient to provide a minimum 'film' thickness of 0.5mm evenly distributed along the length of main to be disinfected.

4.18.5 The spray chlorinator shall be winched through the pipe and not hand pulled and will be capable of providing a printout (that will be kept for record purposes) showing draw rate, flow, thickness of 'film' that the spray head functioned throughout the pull, the length of main disinfected, the amount of solution used and the date and time of disinfection.

4.18.6 As soon as the spray chlorinator head exits the pipe the main must be capped to protect it from post disinfection contamination. It is particularly important to ensure that contamination does not occur due to back siphonage of water into the lined pipe as a result of flooding of the works. Such protection of the main will remain in place up to the point that the main is 'pieced up' to the live main.

4.18.7 Charging up the main should 'absorb' the residual chlorine spray within the main thereby avoiding the need for extensive flushing. The chlorine residual should be checked using a comparator, and the main flushed until the normal required background level of chlorine is achieved. At this point bacteriological, chemical and aesthetic samples are taken for laboratory analysis.

4.19 Rectification of Lining Faults (OR 6.12)

This section describes the more common faults and provides basic instructions for rectification.

A pipe length exhibiting any fault that is related to the application of faulty mix-ratio, severe water damage, unmixed material or single component application shall not be returned to service before rectification as described below.

Lining faults where the **Utility Representative** is satisfied that the lining is correctly proportioned and cured (that is, physical lining faults) may be rectified after the cure period and CCTV inspection as specified in the IFU. Such linings may also be returned to service but shall be rectified within a reasonable timeframe at the discretion of the **Utility Representative**. Where rectification requires overcoating this shall only be carried out using the same material and where possible should be conducted before the main is returned to service. When this is not possible the original coating shall be cleaned to ensure that the surface is free of debris and organic films, etc. that may limit adhesion and long term durability.

If a proportion of the lining is acceptable and the remainder is faulty, the main can be split and the acceptable section returned to service. The faulty lining shall be rectified or replaced before return to service and details of all works carried out on each section shall be recorded on the relevant quality assurance record sheets.

4.19.1 Lining over debris

Inadequate pipe cleaning that has not been identified by CCTV inspection after cleaning may leave corrosion deposits and/or loose debris in the pipe that can be incorporated into the lining or lined over. It is possible that this may cause premature failure of the lining and decrease the expected hydraulic performance of the lined pipe.

If the fault is localised it is best rectified by excavation and removal of the faulty pipe which can be replaced with a suitable make-up piece. However, if the faulty section is extensive, it shall be re-laid, if not able to be adequately cleaned and overlined.



Figure 5 - Debris trapped in applied lining

4.19.2 Ridged lining

Ridged linings (ringing) may be caused by persistent jerking of the lining head in the main as a result of poor design or snagging of the umbilical/hoses on bends and fittings. It can also be caused by winch gear malfunction. Provided the mix-ratio is correct, the troughs are at least 1mm thick and the **Utility Representative** considers the ridge peaks acceptable, no remedial action is required.

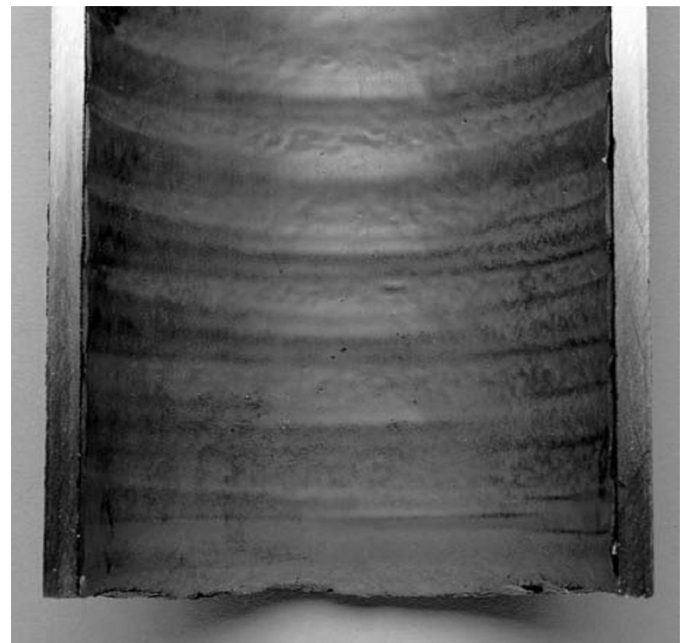

Figure 6 - Ridged lining

A ridged lining with any part below the 1mm minimum (or minimum specified thickness) will generally require remedial action and in any case will require a non-conformance record to be completed. Ridging considered excessive and unacceptable to the **Utility Representative** will similarly require remedial action and a non-conformance record to be completed.

Short sections can again be cut out and replaced with a make-up section. Larger sections will need to be relined or, where ridging is considered excessive and unacceptable, re-laid. If the peaks are thick and/or ragged then driving power boring rods and cutters through the main is recommended. This action will not remove the coating but could remove any obstructions to the subsequent free passage of the lining head. Care should be taken to prove the main before relining is attempted.

Following relining, the curing, inspection and return to service procedures are as described previously.



Figure 7 - Severely ridged lining

4.19.3 Incomplete lining

An intermittent fault on the lining machine or a severe jerking action of the lining head caused by poor adjustment of the skids or winch action, unsatisfactory design of the application head, or protruding obstacles in the main may result in sections of main with no coating.



Figure 8 - Incomplete lining

These faults are usually only observed on post-lining CCTV inspection and the rectification procedure depends upon the magnitude of the fault.

Generally this type of lining fault manifests itself as a single short unlined section (1-2m) in a lining length and this is best dealt with by excavation and replacement with a suitable make-up piece.

Provided the **Utility Representative** is satisfied that the mix-ratio of the lined sections is correct, larger unlined sections or multiple sections will be more cheaply rectified by relining. Following relining, the curing, inspection and return to service procedures are as described previously.

4.19.4 Thin linings

Thin linings are usually identified during CCTV inspection where the host pipe substrate may show through the coating, or more reliably when pipe samples have been taken. Remedial action is as for CP 4.19.3 (Incomplete lining).



Figure 9 - Thin lining



Figure 10 - Slumped Lining

4.19.5 Linings with invert slump

Except when considered unacceptable by the **Utility Representative**, an invert slump can be tolerated provided the thickness at the clock positions of 3, 9 and 12 is within the minimum specification requirement. However, where a coating is below the specification thickness at 3, 9 and 12 it shall be rectified following the recommendations in CP 4.19.3 (Incomplete linings).

Slumped linings considered excessive and unacceptable to the **Utility Representative** will require remedial action.

Where the unacceptable slump is over short sections, this is best dealt with by excavation and replacement with a suitable make-up piece. Longer sections may need to be re-laid, since it is unlikely that the slumped lining will be removed by (say) rack boring. In any case, a non-conformance record shall be filled in.



Figure 11 - Severe slumping



Figure 12 - Effect of lining through water

4.19.6 Lining through water

On occasions water may collect in a low point in the main as a result of water passing from a ferrule or valve after the pre lining CCTV inspection and before lining hose insertion. This type of fault is usually observed after the post-cure CCTV inspection.

Lining through standing water is regarded as severe water damage and the main shall not be returned to service until the fault has been rectified to the satisfaction of the **Utility Representative**.

CCTV inspections shall be conducted in both directions to establish the precise position and extent of the problem. Care shall be taken when conducting CCTV surveys to ensure that potentially uncured resin material is not spread over the remaining lining by the camera.

Where the damage is over short sections, it is best dealt with by excavation and replacement with a suitable make-up piece. Longer sections may need to be re-laid.



Figure 13 – Minor water damage

4.19.7 Invert water damage

Invert water damage may take two forms. The first, illustrated in Figure 13, occurs where water has



Figure 14 - Major water damage

passed over the partially cured lining but does not cause severe damage. Provided the water-damaged area is intact and has a thickness above the minimum specified, no further action is required. Lining damage as shown in Figure 14 is caused by water flowing down the invert immediately after lining. Where the damage is over short sections, it is best dealt with by excavation and replacement with a suitable make-up piece. Longer sections may need to be re-laid.

4.19.8 Presence of unmixed base or activator

In the event of an unobserved fault occurring in the lining machine, or a burst base or activator hose resulting in the application of an unmixed component, or contamination of the inside of the pipe with an unmixed component, the main shall be isolated and not returned to service until rectified.

This lining fault is potentially the most hazardous and strict adherence to these guidelines is mandatory.

Short lengths of uncured component lining would only be witnessed on CCTV inspection and contamination of the CCTV equipment can be expected.



Figure 15 - Unmixed resin material

Rectification of the fault shall require complete isolation of the affected section and may require further customer warning and the installation of bypass arrangements and temporary supplies.

As required by OR 6.12, this lining fault shall be rectified by relaying the contaminated length.

4.19.9 Blistered lining and blowholes

Blisters have been observed in coatings of certain spray-applied materials. This may be observed during CCTV survey and pipe sampling as slightly raised hollow blisters, ranging from a few mm to 3 to 5 cm in size.



Figure 16 - Blistered lining

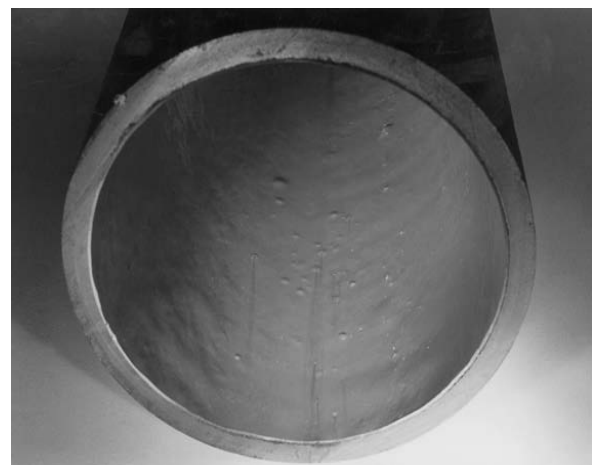

Figure 17 – 'Blowholes' in lining

The decision to undertake rectification is a matter for engineering judgement. Localised blistering can be rectified using local repair procedures. Linings that exhibit substantial quantities of blisters can be power bored, swabbed and over-coated.

Blowholes can occur occasionally. Some blowholes are in effect large pinholes with direct penetration to the cast iron substrate whereas others are blemishes that have sealed and are of no consequence.

The decision on whether or not to rectify this fault is at the **Utility Representative's** discretion. If it is localised, the section of pipe can be cut out. However, if the problem is widespread and severe, rectification shall be carried out as described in previous sections.

Note: The exact reasons for both blowhole formation and blistering are not known, but they may well be formed due to an interaction between the pipe substrate (and/or previous coatings) and resin material. If blowhole and blistering is a significant problem on a particular scheme, it could be that *in situ* lining is not suitable and that other rehabilitation techniques should therefore be considered.

4.19.10 Speckled linings

Speckled linings can be observed during CCTV inspection and occasionally on pipe samples. Surface speckling of the coating may be caused by poor cleaning – loose friable corrosion deposits left in the main are disturbed by the passage of the application head resulting in a surface contamination of the coating by the dust.

Speckled linings can also be localised at joints where loose deposits often remain lodged in the joint cavity. When disturbed, this 'contaminates' a short section of coating either side of the joint. It is essentially an aesthetic problem and the lining may be returned to service at the **Utility Representative's** discretion. Linings unacceptable to the **Utility Representative** shall be over coated.

Simple localised joint contamination needs no rectification provided the coating is intact.

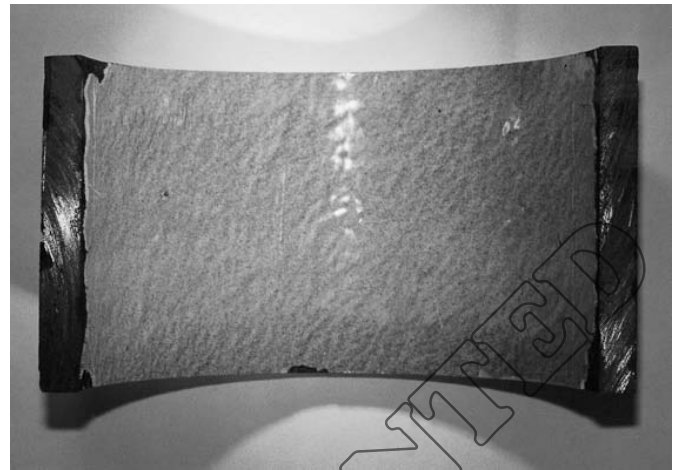

Figure 18 – Speckled lining

4.20 Quality Control Documentation (OR Section 7)

The **Approved Contractor** is responsible for ensuring that all documentation is issued to the **Utility Representative** within the prescribed timescales.

The form of Quality Control documentation used in lining contracts shall conform to the minimum content specification given in Appendix E of the OR⁽¹⁾.

Example standard documents are contained in Appendix B of this Code of Practice. No copyright attaches to these forms and they may be freely reproduced.

4.21 Post Reconnection Problems

This section provides information on the most commonly observed problems following renovation. Rectification procedures are briefly outlined.

4.21.1 Ferrule blockage

Ferrule blockage may occur occasionally and usually as a result of cleaning debris being forced into the ferrule. The normal procedure for rectification is to clear the obstruction by means of a pressurised blow back through the boundary stop tap using, for example, a small cylinder of compressed air, carbon dioxide, or nitrogen.

Where this technique is unsuccessful or cannot be used the ferrule would need to be excavated by hand and cleaned or replaced.

4.21.2 Customer complaints

Customer complaints of discoloured water, poor flow, or pressure can be received despite conducting the rehabilitation in accordance with the Operational Requirements ⁽¹⁾.

The complaints of dirty water may be due to debris swept in from an upstream section or due to the condition of the service pipe. Any problems experienced with service pipes can normally be resolved by on-site personnel using conventional methods.

4.21.3 Problems with fittings and appliances

Problems with fittings and appliances (such as float valves, instantaneous water heaters, automatic washing machines and dishwashers) may present themselves as a result of corrosion debris being swept into a customer's premises after return to service. On-site personnel or an on-call plumber can often resolve the blockage of the float valve or appliance filter.

Water Undertakers and **Approved Contractors** have well designed Customer Care arrangements for mains rehabilitation work. These shall be followed in all appropriate circumstances.

REFERENCES

1. WIS 4-02-01 "Operational Requirements: *In Situ* Resin Lining of Water Mains". Water UK 2009.
2. "List of Approved Products" available at (<http://www.dwi.gov.uk/31/approvedproducts/solist.shtm>) for England and Wales. (<http://www.ehsni.gov.uk/environment/drinkWater/regulations.shtml#dwiilist>) for Northern Ireland and (<http://www.scotland.gov.uk/Publications/2007/03/08102144/0>) for Scotland.
3. WATER UK. The Principles of Water Supply Hygiene and Technical Guidance Notes. Water UK, 1996 (Supplemented 1998).

Code of Practice:

In Situ Resin Lining of Water Mains

Appendix A: Description of the “Whirlwind” or equivalent Pipe cleaning technique.

A.1 Prior to resin lining the pipe may be cleaned by using the Whirlwind or equivalent pipe cleaning technique as an alternative to more traditional techniques such as rack feed boring or drag scraping. This involves blowing dry, washed aggregate down the pipe at high speed until all water, tuberculations, loose deposits or deteriorated remains of a previous coating and other foreign materials from inside the pipe have been removed. The cleaning method used shall not remove areas of graphitisation and shall leave the bore of the pipe dry, smooth, intact and free from dust to ensure a secure bond for any spray lining to be applied, and not to provide any sharp promontories which may damage the lining.

A.2 The aggregate used should be dust free, dry granite or flint that meets the equipment manufacturer's specification. The aggregate and removed deposits will be collected in an enclosed receptacle at the end of the main and upon completion of cleaning of the pipe the contents of the vessel will be disposed of in an environmentally safe manner which may involve them being buried in a suitable on-site operation

A.3 Suitable precautions must be taken to protect operatives and the public from injury during the use of all types of cleaning equipment.

Code of Practice:

***In Situ* Resin Lining of Water Mains**

**Appendix B: Example Quality Control
Documentation**

UNCONTROLLED IF PRINTED

APPENDIX B: EXAMPLE QC DOCUMENTATION

Example standard documents are presented below. No copyright attaches to these forms and they may be freely reproduced. Example documents given are:

- RESIN LINING RECORD
- CCTV RECORD
- NON CONFORMANCE RECORD
- PIPE SAMPLE QUALITY RECORD
- SPIN-UP DETERMINATION RECORD

UNCONTROLLED IF PRINTED

Insert your company logo here

Serial Number:

RESIN LINING RECORD (All items to be completed)

Scheme/ Location

Contract	<input type="text"/>	Access Hole Refs.	<input type="text"/>
Contractor	<input type="text"/>	Pipe Diameter	<input type="text"/>
Supervisor	<input type="text"/>	Pipe Material	<input type="text"/>
Gang Ref.	<input type="text"/>	Resin Material	<input type="text"/>
Date	<input type="text"/>	Length Lined	<input type="text"/>

Lining rig number	<input type="text"/>	Quantity	<input type="text"/>
Application head number	<input type="text"/>	Quantity	<input type="text"/>
Length of static mixer	<input type="text"/>		
Base batch numbers	<input type="text"/>		
Activator batch numbers	<input type="text"/>		

Cleaned: visual checks OK?	YES	NO	Method used	Rackbore	Drag scrape
Cleaned: CCTV survey OK?	YES	NO		Number of swabs	<input type="text"/>

Ambient temperature	°C	Pipe wall temperature	°C
Base temperature	°C	Activator temperature	°C
Lining: time start	<input type="text"/>	Spin-up time	(Mins)
Lining: time complete	<input type="text"/>		

WEIGHT CHECK 1			
Test No.	Weight of base (B)	Weight of activator (A)	Mix-ratio = (A/B)x100
1	<input type="text"/>	<input type="text"/>	<input type="text"/>
2	<input type="text"/>	<input type="text"/>	<input type="text"/>
3	<input type="text"/>	<input type="text"/>	<input type="text"/>
Time of Test No. 3		<input type="text"/>	

WEIGHT CHECK 2: PRE/POST LINING			
Test No.	Weight of base (B)	Weight of activator (A)	Mix-ratio = (A/B)x100
1	<input type="text"/>	<input type="text"/>	<input type="text"/>
2	<input type="text"/>	<input type="text"/>	<input type="text"/>
3	<input type="text"/>	<input type="text"/>	<input type="text"/>
(If required)			

Weight check 1 OK?	YES	NO
Mix-ratio print out OK?	YES	NO

Weight check 2 OK?	YES	NO
Tab test OK?	YES	NO

INSPECTION		PRE-CURE	
Uniformity OK?	YES	NO	
Quality OK?	YES	NO	
Thickness OK?	YES	NO	
Hardness OK?	YES	NO	

POST CURE	
YES	NO
YES	NO
YES	NO
YES	NO

Curing time: start	from exit of machine
	from pipe

Curing time: finish	when post cure inspection is complete
---------------------	---------------------------------------

Duration of cure	<input type="text"/>	
CCTV survey OK?	YES	NO

Tack free	YES	NO
CCTV Record number	<input type="text"/>	

Disinfectant concentration at start of contact time	mg/l	
Contact time	hrs	
Dechlorinated?	YES	NO
Reconnection date	<input type="text"/>	
Pipe sample record number	<input type="text"/>	
Non-conformance record no.	<input type="text"/>	

Disinfectant concentration at end of contact time	mg/l	
Flushing time	<input type="text"/>	
Where discharged	<input type="text"/>	
Reconnection time	<input type="text"/>	
Water quality results OK (chlorine, turbidity, taste, odour, appearance, coliform, E.coli)?	YES	NO

Comments:

For Client

Signature

Print name

Position

Date

For Contractor

Signature

Print name

Position

Date

Insert your company logo here

Serial Number:

RESIN LINING CCTV RECORD

Scheme/ Location

Contract
Contractor
Supervisor
Gang Ref.
Date am/pm

Access Hole Refs.
Length Surveyed
RLR Number
Resin Material

CCTV recording reference

Faults observed	Position	Comment 1	Comment 2
Incomplete lining			
Water damage			
Slump			
Ridging/ Ringing			
Mix-ratio error			
Single component			
Blisters / blowholes			
Hard scale / deposits			
Poor cleaning			
Other			

CCTV TO BE WITNESSED BY CLIENT

For Client

Signature
Print name
Position
Date

For Contractor

Signature
Print name
Position
Date

Remedial action required? YES NO

Remedial action taken? YES NO

NCR number

Pipe sample taken? YES NO

PSQR number

Contractor's Representative

Signature
Print name
Position
Date

Insert your company logo here

Serial Number:

RESIN LINING NON CONFORMANCE RECORD

Scheme/ Location

Contract	<input type="text"/>	Access Hole Refs.	<input type="text"/>
Contractor Supervisor	<input type="text"/>	Resin Material	<input type="text"/>
Gang ref.	<input type="text"/>	RLR Number	<input type="text"/>
Date	<input type="text"/>	Length Lined	<input type="text"/>

Nature of defect

Reason for defect

Action taken

Date of action **RLR Number (if relined)**

Action taken to prevent recurrence

Comments

For Client

Signature	<input type="text"/>
Print name	<input type="text"/>
Position	<input type="text"/>
Date	<input type="text"/>

For Contractor

Signature	<input type="text"/>
Print name	<input type="text"/>
Position	<input type="text"/>
Date	<input type="text"/>

Insert your company logo here

Serial Number:

RESIN LINING PIPE SAMPLE QUALITY RECORD

Scheme/ Location			
Contract		Access Hole Refs.	
Contractor		Resin Material	
Supervisor		RLR Number	
Gang Ref.		Length Lined	
Date			

END 1

(Position)	3 o'clock	6 o'clock	9 o'clock	12 o'clock
Thickness (mm)				

Mean Max Min

END 2

(Position)	3 o'clock	6 o'clock	9 o'clock	12 o'clock
Thickness (mm)				

Mean Max Min Lining accepted? YES NO

LINING FAULTS

Faults observed	(tick)	Comments
Incomplete lining		
Water damage		
Slump		
ridging/ Ringing		
Mix-ratio error		
Inadequate cure		
Blisters		
Poor cleaning		
Other		

PIPE CONDITION

	(tick)	Comments
Oval		
Undersize		
External light corrosion		
External medium corrosion		
External heavy corrosion		

Comments:

Photographs taken YES NO
NCR number issued (if any)

Attach any photographs or negatives to record

Sample passed to client:
Inspection Office

Date

For Client

For Contractor

Signature
Print name
Position
Date

Signature
Print name
Position
Date

Insert your company logo here

Serial Number:

RESIN LINING SPIN-UP DETERMINATION RECORD

For method see Operational Requirements Appendix D

Scheme/ Location			
Contract Supervisor		Resin Material	
Gang Number		Rig Type	
Date		Rig Number	
Total Flow Rate	(l/min)	Ambient Temperature	°C
		Umbilical Temperature	°C
		Base Temperature	°C
		Activator Temperature	°C

TEST RESULTS

Elapsed Time	Colour Correct		Assessment of Cure
10s	YES	NO	
20s	YES	NO	
30s	YES	NO	
40s	YES	NO	
50s	YES	NO	
60s	YES	NO	
70s	YES	NO	
80s	YES	NO	
90s	YES	NO	
100s	YES	NO	
110s	YES	NO	
120s	YES	NO	

Tab cure time		Date tested	
Min. acceptable spin up time	(mins)		

Note: This is the time of the tab having the correct colour and cure plus 30 seconds. Minimum allowable time: 1 minute for fast-setting resins or 1 minute 30 seconds for epoxy resins.

Test carried out by

Witness by client

Signature	
Print name	
Position	
Date	

Signature	
Print name	
Position	
Date	