

---

---

# WATER INDUSTRY SPECIFICATION

---

---

**WIS 4-37-01**  
November 1990: Issue 1  
(Page 1 of 14)  
ISSN 0956-5132

Reprinted June 2006  
for web publication

UK Water Industry

---

## SPECIFICATION FOR BOUNDARY BOXES FOR THE METERING AND CONTROL OF DOMESTIC AND SMALL INDUSTRIAL WATER SERVICES

---

### FOREWORD

This specification was prepared by WRc plc under the direction of the Water Services Association/Foundation for Water Research Sewers and Water Mains Committee in consultation with the Water Industry to define the properties required of boundary boxes for the metering and control of domestic and small industrial water services.

This document includes basic performance-related type tests and quality control tests which have been agreed by the Water Industry.

Purchasers are reminded that this specification requires that the manufacturer shall operate a quality system relating to the manufacture of products to this specification in compliance with BS 5750: Part 2 (EN 29002) which ensures that products claimed to comply with this specification consistently meet the required level of quality. Enquiries regarding the availability of third party NACCB or equivalent accredited certification body or to WRc.

Compliance with this specification does not itself confer immunity from legal obligations.

This specification does not purport to include all the necessary provisions of a contract. Users of this specification are responsible for its correct application. Reference to a British Standard, Water Industry Specification or any other specification applies equally to any equivalent specification.

This specification includes the use of substances and/or procedures that may be injurious to health if adequate precautions are not taken. It refers only to technical suitability and does not absolve the user from legal obligations relating to health and safety at any stage.

It has been assumed in the drafting of this specification that the execution of its provisions is entrusted to appropriately qualified and experienced people.

Information contained in this specification is given in good faith. Neither the Foundation for Water Research, WSA nor the WRc can accept any responsibility for actions taken as a result.

### CONTENTS

#### FOREWORD

1. SCOPE
2. DEFINITIONS
  - 2.1 Boundary box
  - 2.2 Rigid (R) or Telescopic (S)
  - 2.3 Manifold
  - 2.4 Watertightness
3. QUALITY ASSURANCE
4. PERFORMANCE TESTING
  - 4.1 Type testing
  - 4.2 Quality control testing
5. MATERIALS
  - 5.1 External components
  - 5.2 Effect on water quality
6. GENERAL DESIGN REQUIREMENTS
  - 6.1 Design life
  - 6.2 Watertightness

---

Technical enquiries to:  
WRc, Frankland Road, Blagrove, Swindon, Wilts, SN5 8YF Tel: (01793) 865151 E-mail: [wisign@wrcplc.co.uk](mailto:wisign@wrcplc.co.uk)

- 6.3 Load bearing capacity
- 6.4 Load distribution
- 6.5 Existing service depth range
- 6.6 Access dimension
- 6.7 Cover height adjustment
- 6.8 Width of guard tube
- 6.9 Depth to meter register
- 6.10 Manifold environment
- 6.11 Hydraulic head loss
- 6.12 Product information
- 6.13 Marking

**7. TECHNICAL REQUIREMENTS OF COMPONENTS**

- 7.1 Surface box/cover and frame assembly
  - 7.1.1 Materials
  - 7.1.2 Dimensions of surface box/cover or lid assembly
  - 7.1.3 Displacement
  - 7.1.4 Angular adjustment
  - 7.1.5 Self draining facility
  - 7.1.6 Ease of removal
  - 7.1.7 Detection facility
  - 7.1.8 Removal facility
  - 7.1.9 Marking
- 7.2 Guard tube
  - 7.2.1 Purpose
  - 7.2.2 Materials
  - 7.2.3 Non-attachment
  - 7.2.4 Range of adjustment
  - 7.2.5 Width
  - 7.2.6 Insulation
- 7.3 Main body and manifold
  - 7.3.1 Content
  - 7.3.2 Materials
  - 7.3.3 Manifold assembly
  - 7.3.4 Meter housing point
  - 7.3.5 Dewatering facility
  - 7.3.6 Stop valve
  - 7.3.7 None-return valve
  - 7.3.8 Inlet and outlet pipework
  - 7.3.9 Pressure resistance
- 7.4 Base unit
  - 7.4.1 Purpose
  - 7.4.2 Materials
  - 7.4.3 Attachment
  - 7.4.4 Load distribution

**8. TEST CONDITIONS**

**9. ASSEMBLY INSTRUCTIONS**

**10. REFERENCES**

**APPENDICES**

- A. Top Loading: Type Tests
- B. Freezing: Type Test

- C. Hydraulic Performance Head Loss: Type Test
- D. Pressure Release Mechanism: Type Test
- E. Hydraulic Pressure: Type Test/Quality Control Test
- F. Watertightness: Type Test/Quality Control Test
- G. Insulation Material Durability: Type Test

**1. SCOPE**

This specification is intended to apply to proprietary purpose-made boundary boxes which are to be designated either as category Class 1 (watertight) or as category Class 2 (non-watertight) as defined by type testing.

The specification covers the basic components, design parameters and technical requirements of single meter boundary boxes capable of accommodating a range of concentric or end-fitting small revenue water meters up to and including a Qn (nominal flowrate) of 2.5 cubic metres per hour.

**2. DEFINITIONS**

**2.1 Boundary box**

In the context of this specification a boundary box is a complete, purpose-made measurement and flow control unit for installation underground on a water service at or adjacent to the boundary of the property or curtilage. The unit will normally comprise a number of separate or contiguous basic components including at least a base (incorporating the inlet and outlet to the box), the main body housing the flow measurement and control mechanisms combined in a manifold, a guard tube, and a surface box/cover and frame assembly. These basic components and terminology are illustrated diagrammatically in Figure 1.

Boundary boxes shall be designated either as category Class 1 (watertight) or Class 2 (non-watertight).

The category of the box shall be further designated by reference to its basic design principle and load bearing capacity abbreviated as follows:

- Rigid (R) or telescopic/sliding head (S);
- Load bearing Grade A, B or C.

Example:

A watertight boundary box designed with a sliding head and capable of withstanding a Grade C loading shall be designated a category "Class 1.S.C" box.

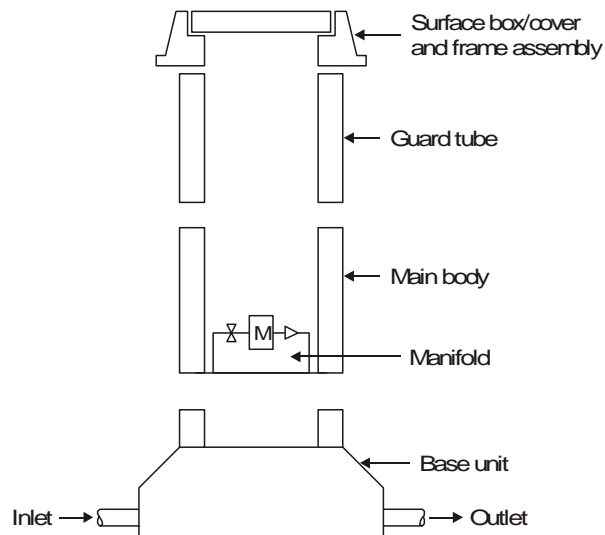

**Figure 1 – Basic components of meter boundary box: Terminology**

Note: This figure is diagrammatic and is intended only to identify the terminology given to the component parts of a boundary box. This configuration is not intended to illustrate or imply any particular design, make or style of boundary box.

## 2.2 Rigid (R) or Telescopic (S)

In this context a rigid box is defined as one in which all (or a major proportion) of the surface loading is transmitted directly through the walls of the boundary box to a base unit. A telescopic or sliding head box is one which enables the surface loading to be distributed from the surface box to the surrounding backfill material with only minimal forces being transmitted to the main body and base of the boundary box. A telescopic box designed for use with rigid spacers shall be given the designating letter R and tested as a rigid box.

## 2.3 Manifold

The term manifold refers to an assembly combining at least a meter housing device (with or without a

meter), a stop valve, a check valve and the connections to the inlet and outlet pipework.

## 2.4 Watertightness

A boundary box shall be considered watertight if water does not enter the internal enclosure as defined in the Watertightness Test (Appendix F).

## 3. QUALITY ASSURANCE

Manufacturers shall operate a quality system relating to this specification in compliance with BS 5750: Part 2 (EN 29002).

## 4. PERFORMANCE TESTING

### 4.1 Type testing

Each design of boundary box shall be subjected to the following Type Tests:

- Top Loading Test (Appendix A)
- Freezing Test (Appendix B)
- Hydraulic Performance: Head Loss Test (Appendix C)
- Pressure Release Mechanism (Appendix D)
- Non-Return Valve (to WIS No. 5-11-01 or BS 6282 as appropriate)
- Hydraulic Pressure Test (Appendix E.2.2)
- Watertightness Test (Appendix F)
- Insulation Material Durability Test (Appendix G).

### 4.2 Quality control testing

Boundary boxes shall be subjected to the following quality control tests:

- Internal Hydraulic Pressure Test (Appendix E.2.1)
- Watertightness Test (Appendix F).

The production quality control activities shall be carried out in accordance with an appropriate and approved sampling schedule.

## 5. MATERIALS

### 5.1 External components

All external box components shall be constructed of corrosion-resistant materials which are compatible with being buried for prolonged periods whilst retaining their dimensional and structural characteristics.

### 5.2 Effect on water quality

5.2.1 Non-metallic materials (in manufactured form) which are in contact with potable water in service shall be tested to and meet the requirements of BS 6920: Part 1.

**NOTE:** Products for installation and use in the United Kingdom which are verified and listed under the UK Water Fittings Byelaws Scheme\* are deemed to satisfy the requirements of this clause.

(\*Water Regulations Advisory Scheme, Fern Close, Pen-Y-Fan Industrial Estate, Oakdale, Gwent, UK. NP11 3EH.)

5.2.2 Metallic materials shall be tested to and meet the requirements of IGN No. 5-01-03.

5.2.3 Pending the determination of suitable means of characterizing the toxicity of leachates for materials in contact with potable water, materials (in manufactured form) shall be approved by the Department of the Environment Committee on Chemicals and Materials of Construction (CCM) for use in Public Water Supply and Swimming Pools as being free from adverse health effects.

**NOTE:** A list of approved chemicals and materials is available from the Technical Secretary of the above Committee, DoE, Water Division, Romney House, 43 Masham Street, London SW1P 3PY.

## 6. GENERAL DESIGN REQUIREMENTS

### 6.1 Design life

The materials used and the design adopted shall seek to ensure a minimum installed asset life of 50 years when subjected to normal operating and maintenance conditions.

### 6.2 Watertightness

For category Class 1 boxes the design of the boundary box shall enable the main body and its

contents to remain free from the ingress of ground and surface water throughout its operational life. Attention shall therefore be paid to the materials employed in constructing the box and especially the joints and sealing rings in such vulnerable areas as:

- cover and frame assembly
- height adjustment facilities of the guard tube
- the manifold housing
- inlet and outlet pipework connections to the main body of the box.

A safe pressure release device shall be incorporated into the design of Class 1 boxes to obviate excess hydraulic upthrust or a dangerous build-up of pressure within the box which may be caused by internal leakage.

### 6.3 Load bearing capacity

The surface box assembly when installed shall be capable of supporting the appropriate loadings as defined and detailed in Appendix A of this specification.

### 6.4 Load distribution

The design of the assembly shall ensure that all vertical load distribution is achieved without undue deformation of the main body of the boundary box or its components and that no stress is directly transmitted to the connecting pipework.

### 6.5 Existing service depth range

The general dimensions of boundary boxes shall be suitable for installation upon existing service pipes laid at depths ranging from 350mm to over 750mm below ground level. This range will require some dimensional variation in one or more components but should not necessarily imply a difference in design concept or operational performance.

### 6.6 Access dimension

The dimensions of the cover shall facilitate meter reading and provide adequate access to the guard tube and main body to retrieve, adjust, operate and maintain their internal component parts without the need to excavate the surround or dismantle the box.

### 6.7 Cover height adjustment

The height of the cover in relation to the main body of the box shall be capable of a vertical dimensional adjustment by convenient intervals of measurement to allow for minor variations in finished ground levels or subsequent alterations to such levels (see 7.2.4).

## 6.8 Width of guard tube

The horizontal internal dimensions of the guard tube shall not normally be less than 105mm nor more than 250mm.

## 6.9 Depth to meter register

When fitted the meter shall be capable of being read without difficulty. The meter shall be installed so that the uppermost waterways are at a level which is at least 300mm below ground level.

## 6.10 Manifold environment

The design of the main body (and/or guard tube) shall ensure that the immediate environment of the meter and the manifold assembly:

- remains frost free under external temperatures equivalent to those described in Appendix B: Freezing Test,
- is not conducive to condensation,
- has minimal risk of contamination during both operational and maintenance procedures.

## 6.11 Hydraulic head loss

The hydraulic head loss shall not be greater than 3 metres of water when the whole box assembly, fitted with a rotary piston meter complying with Class D of BS 5728: Part 1 and having a nominal flow rate of  $Q_n = 1.0\text{m}^3/\text{hour}$ , is operating at a flow rate of 25 litres/minute. Details of this test are given in Appendix C. In defining the head loss the manufacturer must identify the make of meter used in testing.

## 6.12 Product information

Suppliers shall provide for each design

- a category designation based on watertightness, design principle and load bearing capacity as described in 2.1,
- a definition of the range and type of meter(s) which the manifold will accept directly and details of any adaptation that will be required to accommodate alternative meters,
- descriptive drawings in sufficient detail for the design principles to be understood by the operative,
- clear instructions on the recommended installation procedures including advice on backfilling and reinstatement requirements to obtain maximum structural performance of the box,
- a recommended maintenance statement giving full details of procedures, frequencies, sparepart schedules and any special tools or equipment necessary to permit the necessary and correct maintenance of the product throughout its minimum asset life,
- a statement drawing attention to the materials of construction,
- such other information or documentation as may be required by the purchaser in respect of their product.

## 6.13 Marking

Boundary boxes manufactured to this specification shall be clearly and permanently marked. No method of marking shall prejudice the performance of the box when tested to the requirements of this specification.

The marking shall give the following information:

- (a) the manufacturer's identification,
- (b) the pressure rating,
- (c) batch identification,
- (d) the word "WATER" (in accordance with 7.1.9 of this specification),
- (e) direction of flow through boundary box.

In addition, the following marking may also be included:

(f) the number of this specification i.e. WIS 4-37-01. The use of this mark is a claim by the manufacturer that the product has been manufactured in accordance with the requirements of this specification and the claim is solely his responsibility,

(g) a third party certification mark (if permissible).

## 7. TECHNICAL REQUIREMENTS OF COMPONENTS

### 7.1 Surface box/cover and frame assembly

#### 7.1.1 *Materials*

The cover (or lid) and its frame shall be of cast iron, ductile iron, aluminium or an appropriate plastics material as specified in BS 5834: Parts 2, 3 or 4 or other materials of equal performance.

The cover shall have slip-resistance properties. All materials used shall have physical and chemical properties such that this component is capable of withstanding:

- prolonged severe frost (Appendix B),
- high temperatures (typically those of hot-rolled asphalt, i.e. maximum 120°C),
- prolonged UV exposure (i.e. strong sunlight),
- the specified wheel loading,
- impact loading (equivalent to a conventional light duty vibrating roller or grass cutting machinery),

without failure, pronounced embrittlement, undue distortion or polymer degradation throughout its asset life(see section 6.1).

#### 7.1.2 *Dimensions of surface box/cover or lid assembly*

The dimensions of the clear opening shall be the minimum which permits ready access and adequate working width to perform the following possible activities:

- install and retrieve the meter blanking cap,
- install and retrieve the specified range of meter,
- read the meter register easily,
- operate, remove and/or maintain the control valve,

- replace and/or maintain the non-return valve,
- install and retrieve any additional facilities listed under 7.3.4,
- install and retrieve any necessary insulation.

#### 7.1.3 *Displacement*

The design of the cover and frame shall be such that these will not be permanently displaced under normal traffic and operational conditions.

#### 7.1.4 *Angular adjustment*

Where specified the cover and frame shall be capable of adjustment to meet the slope of the surrounding surface independently of the main body of the box to a nominal 5° from horizontal. In all cases, rectangular covers shall have the additional facility of horizontal rotation.

#### 7.1.5 *Self draining facility*

The surface of the cover or lid shall be self draining but the design of the cover and frame for Class 1 boxes shall additionally prevent the ingress of surface water to the main body of the boundary box.

#### 7.1.6 *Ease of removal*

The design of the cover and frame shall be such that the cover or lid is easily opened preferably by the use of a commonly available handtool.

**NOTE:** The purchaser should specify in his enquiry and/or order whether the cover/lid should have securing, locking or spring release facilities. In Class 1 boxes, pressure release facilities may also be incorporated into the cover/lid under the requirement of 6.2 of this specification.

#### 7.1.7 *Detection facility*

Non-metallic covers and lids shall be provided with a corrosion-resistant or suitably protected metal component moulded into or permanently fixed to the underside of the cover to facilitate detection when using a conventional hand-held electronic surface box finder. The metal of the component shall have a minimum plan area of 5000mm<sup>2</sup> and have a minimum thickness of 1mm.

**NOTE:** This requirement must be read in the context of the possible requirement for the meter to be read electronically through the lid.

#### 7.1.8 *Removal facility*

The design shall be such that, once the boundary box has been properly installed, future work on the cover

and frame for realignment or height adjustment purposes shall be able to be carried out without disturbing the main body of the box.

### 7.1.9 **Marking**

The word "WATER" shall be permanently incorporated into the cover or lid. Any other identification marks shall be by arrangement between the purchaser and manufacturer.

## 7.2 **Guard tube**

### 7.2.1 **Purpose**

The guard tube shall serve the following purposes:

- firmly locate but not necessarily fully support the surface box/cover and frame assembly,
- adequately support the external backfill material and withstand its loading,
- provide adequate free working space to carry out operational, repair or maintenance work on the manifold assembly,
- provide space and location for the provision of insulating material to protect the meter and manifold from frost, condensation or possible damage.

### 7.2.2 **Materials**

The materials used for the guard tube shall comply with 5.1 of this specification.

### 7.2.3 **Non-attachment**

The design shall allow for the guard tube to firmly locate but not necessarily form an integral part of the cover frame. A facility to remove the cover and frame for adjustment or replacement shall be provided (6.7). For Class 1 boxes the connections between the cover frame, guard tube and main body shall provide a watertight seal at all times.

### 7.2.4 **Range of adjustment**

The length of the guard tube shall be capable of a minimum adjustment of 150mm by increments of not more than 10mm (6.7).

### 7.2.5 **Width**

The horizontal dimensions of the guard tube shall not normally be less than 105mm nor more than 250mm as specified in 6.8.

### 7.2.6 **Insulation**

The guard tube and/or main body shall incorporate sufficient water repellent insulating material such as is required to provide an equable environment for the meter and manifold assembly to comply with 6.10.

The durability of the insulation material, where supplied, shall enable the requirements of Appendix G to be met.

## 7.3 **Main body and manifold**

### 7.3.1 **Content**

The main body of the box shall contain a manifold assembly incorporating at least the following:

- a meter installation point,
- a standard stop tap or valve conforming to 7.3.6,
- a check valve conforming to 7.3.7,
- inlet and outlet pipework and/or unions.

### 7.3.2 **Materials**

The materials used in the main body and manifold shall comply with 5.1 and/or 5.2 as appropriate.

### 7.3.3 **Manifold assembly**

The manifold assembly shall be securely fixed to the main body so as to prevent any relative movement during installation, operation, subsequent maintenance or replacement work.

For Class 1 type boxes the inlet and outlet pipework connections through the base of the main body shall have watertight unions or seals.

There shall be adequate clearance between all manifold fittings and the internal walls of the main body to facilitate component replacement and/or normal maintenance procedures.

As far as practicable all manifold and pipe joints (other than the external joints of the tail pipes) shall

be visible within the main body of the box when correctly installed.

#### 7.3.4 **Meter housing point**

The meter installation point for concentric meters shall be supplied with an appropriate removable blanking cap (or plate) which when in position positively seals the orifice but does not restrict the flow of water through the assembly.

On removal of the blanking cap the locating design must be such as to easily and positively accommodate the specified range of meters without adaptation.

**Note 1:** Suppliers should clearly indicate the range of alternative meters and any other facility that may be accommodated by means of adaptation of the meter installation point, (see 6.12).

**Note 2:** By using special adaptors this installation point may provide the following facilities:

- total flow isolation,
- flow restriction,
- sampling point,
- pressure measurement.

**Note 3:** A facility to secure the meter against tampering or illegal removal may be required.

**Note 4:** The purchaser should specify in his enquiry and/or order whether any or all of these additional features are required.

#### 7.3.5 **Dewatering facility**

Sufficient free volume shall be allowed below all manifold openings to receive any residual water discharge which may occur on removal of the meter. A facility for dewatering the interior of the box at least to below the level of the manifold openings should be incorporated into the design.

#### 7.3.6 **Stop valve**

An approved stop valve (stop tap) shall be incorporated into the manifold upstream of the meter and so positioned that repair or maintenance can be carried out in situ.

The following types of the valves are acceptable:

- Stopvalves to BS 5433 and/or WIS No. 4-23-04,
- Plug cocks to BS 2580 and/or WIS No. 4-23-04,

- Other stop valves suitable for underground use and listed in the current edition of the Water Fittings and Materials Directory.

#### 7.3.7 **Non-return valve**

A non-return valve shall be incorporated into the downstream side of the meter and be so positioned that retrieval for maintenance and/or replacement can be carried out in situ.

In the absence of an appropriate British Standard the non-return valve shall comply with WIS No. 5-11-01.

#### 7.3.8 **Inlet and outlet pipe work**

All materials comprising the inlet and outlet pipework (including joints) shall comply with the requirements set out in 5.2 of this specification.

The joints connecting the manifold assembly to the inlet and outlet pipework should preferably be formed within the main body and be visible internally on completion of the box installation (7.3.3).

In Class 1 boxes, pipework passing into and out of the main body shall have specifically-designed leak-proof unions or seals at the passing points.

The inlet and outlet pipework shall normally be 25mm SDR11 blue medium density polyethylene (MDPE) to BS 6572. Alternative material may be acceptable providing it complies with all other applicable requirements of this specification and can be demonstrated to have equal or better performance characteristics.

All configurations of the pipework shall comply with those standards and recommendations acceptable to the Water Services Association and be carried out in a manner approved by the pipe manufacturer.

Where the pipework tails pass out through the base unit the design shall be such that the pipework is adequately located and held sufficiently firm to enable jointing of the tails to be carried out satisfactorily without undue movement. On completion of the work the design should ensure that the pipework will not be subjected to any stress due to the loading on the boundary box cover and frame (7.4.4).

Where provided both inlet and outlet pipework shall extend a minimum of 150mm outside the box.

Where service pipe connectors form an integral part of the box design they shall conform to the appropriate British Standard, Water Industry Specification or an equivalent standard.

Inlet and outlet terminations shall have temporary plugs or caps fitted for transportation and storage which can be easily removed before installation.

The correct direction of flow through the boundary box shall be clearly and permanently marked in an unambiguous manner.

The whole manifold assembly, with and without a standard Class D meter fitted, shall safely and reliably accommodate a hydraulic pressure of 16 bars for 5 minutes. Details of the Hydraulic Pressure Test are given as Appendix E.

## 7.4 Base unit

### 7.4.1 Purpose

The base unit shall serve the following purposes:

- provide a stabilising platform for the boundary box,
- provide a load distribution area if required,
- form a protected space within which the inlet and outlet pipe tails are capable of being configured without risk of overstressing,
- provide a controlled stress-free outlet facility for the tails,
- provide a means of complying with Byelaw 48 (covering over pipes).

### 7.4.2 Materials

The materials used for the base unit shall comply with 5.1 of this specification.

### 7.4.3 Attachment

Where the base unit does not form an integral part of the main body it shall be firmly located and securely attached thereto by a suitable corrosion-resistant jointing system.

### 7.4.4 Load distribution

Where the base unit is designed to assist in the distribution of top (surface) loading, no load shall be taken directly or indirectly by the inlet and outlet pipes. Sufficient surface area shall be provided for the base to stabilise the boundary box and to safely transmit any imposed load to the formation level

without exceeding the maximum design deflection (6.3).

## 8. TEST CONDITIONS

During type testing or in any case of dispute, specimens shall be conditioned prior to testing at  $23 \pm 2^\circ\text{C}$ , unless otherwise specified, for not less than 24 hours.

## 9. ASSEMBLY INSTRUCTIONS

The manufacturer shall supply instructions for assembly with each fitting.

## 10. REFERENCES

- |         |   |
|---------|---|
| BS 2580 | Specification for underground plug cocks for underground cold water services.   |
| BS 5114 | Performance requirements for joints and compression fittings for use with polyethylene pipes.   |
| BS 5433 | Specification for underground stopvalves for water services.  |
| BS 5728 | Measurement of flow of cold potable water in closed conduits. Part 1: Specification for meters. Part 3: Methods for determining principal characteristics of meters.  |
| BS 5750 | Quality systems<br>Part 2: (EN 29002) Specification for production and installation.  |
| BS 5834 | Surface boxes, guards and underground chambers for gas and waterworks purposes<br>Part 2: Specification for small surface boxes.<br>Part 3: Specification for large surface boxes.<br>Part 4: Specification for preformed chambers. |
| BS 6282 | Specification for devices with moving parts for the prevention of contamination of water by backflow.   |
| BS 6572 | Specification for blue polyethylene pipes up to nominal size 63 for below ground use for potable water.   |

BS 6700	Design, installation, testing and maintenance of services supplying water for domestic use within buildings and their curtilages.
BS 6920	Suitability of non-metallic products for use in contact with water intended for human consumption with regard to their effect on the quality of the water. Part 1: Specification.
IGN No. 5-01-03	Requirements for the testing of metallic materials for use in contact with potable water.
WIS No. 4-23-04	Specification for the requirements for underground stop valves, including spherical valves for water services and made principally of metal or thermoplastics.
WIS No. 5-11-01	Specification for devices with moving parts for the prevention of contamination of water by backflow – check valves of nominal size up to and including DN50.
WRc	Water Fittings and Materials Directory.

**Bearing blocks** whose dimensions are (a) at least as great as the cover of the boundary box to be tested, and (b) greater than the base of the boundary box, faced with hard rubber or other resilient material, and sufficiently rigid to ensure that the load is distributed evenly over the load-bearing surface of the box.

**A device for applying the load.** The device shall be capable of applying a load at least 25% greater than the appropriate load specified in Table 1 of this specification. The device shall be accurate to within 2% of the indicated load.

**A measuring device** suitable for indicating deflection measurements to within  $\pm 0.5\text{mm}$ .

### A.2.2 Test Specimens

The boxes shall be tested in the following manner:

(a) **Rigid boundary box:** The complete assembly is required to be tested and show no signs of permanent deformation or cracking.

(b) **Telescopic (Sliding head) boundary box:** The sliding head assembly shall be tested between the two bearing blocks and show no signs of permanent deformation or cracking. The assembly may be supported under the load bearing flange by a profiled bearing collar.

Where the boundary box is also designed for use with rigid spacers, the complete assembly shall be tested with the spacers in place and tested as a rigid box.

### A.2.3 Procedure

The complete boundary box or sliding head assembly supported by a bearing collar, as appropriate, shall be placed vertically between the two bearing blocks (see Figure 2).

The loading test shall be carried out by applying the Grade C or Grade B design load, as appropriate, specified in Table 1 of this specification, through the bearing block (see A.2.1) placed centrally on the unit being tested.

## APPENDIX A – TOP LOADING: TYPE TESTS

These tests can be used to assess the resistance of boundary box assemblies to surface loading. The tests are designed to monitor the deformation of the **cover and box**.

### A.1 TOP LOADING TEST – SURFACE BOX ASSEMBLY

This test is designed to assess the deformation of the surface box assembly. It is applicable to both rigid and telescopic boxes.

The cover and frame assembly shall be tested in accordance with BS 5834: Part 2: Appendix A using the design loads specified in Table 2 of that specification. Where the minimum clear opening differs in size to BS 5834, the test block diameter shall be equal to the minimum clear opening and the test load calculated as described in BS 5834: Part 2: Appendix A.

### A.2 TOP LOADING TEST – COMPLETE BOUNDARY BOX

#### A.2.1 Apparatus

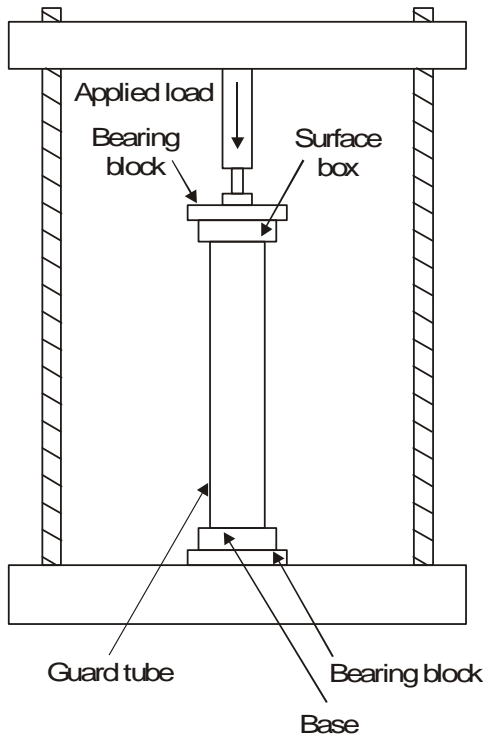

**Figure 2 – Schematic representation of the top loading test equipment**

**Table 1 - Test loads for top-load test as defined in Appendix A**

Design load (Grade C) (kN)	Design load (Grade B) (kN)
$10 \times \frac{a}{70,686}$ or 5 kN whichever is greater	$\frac{150 \times a \times 1.3}{70,686}$

'a' is the total top surface area of the cover in mm<sup>2</sup>.

**A.3 Test Report**

The test report shall include:

- (a) The full identification of the specimen,
- (b) Description of fitting assembly,
- (c) Test conditions,

- (d) Observations and results,
- (e) The date of the test.

**APPENDIX B - FREEZING: TYPE TEST**

This test can be used to simulate the ground conditions during a prolonged surface frost to provide assurance of the boundary boxes' resistance to freezing.

**B.1 APPARATUS**

**An insulated chamber** capable of containing the boundary box installed in representative ground material with a depth of at least 1500mm and enclosing an air space above the box cover and ground surface. The chamber is to be so designed as to be capable of maintaining a temperature profile as specified in B.2.

**A suitable freezer unit** with its low temperature unit installed in the air space of the insulated chamber and capable of reducing the temperature at ground level to a minimum of -15°C.

**Temperature measuring devices** capable of measuring the temperature of the boundary box and its surrounds to an accuracy of ±0.25°C.

**B.2 PROCEDURE**

An approved meter shall be assembled inside the box. The manifold, meter and service pipe tailwork should be filled with water and the service pipe tailwork or inlet/outlet terminations blanked off prior to installation of the box.

The box shall be installed in the chamber such that the cover is level with the top of the chamber. Insert temperature probes at 300 and 1000mm below the top of the chamber. Backfill the chamber and place the freezer unit directly above the box.

Self-draining boundary boxes shall be tested empty and filled with water to a depth of:

- (a) half way up meter,
- (b) full boundary box height.

The temperature of the surrounding backfill shall be lowered by adjustment of the freezer unit and maintained until stable temperatures of  $0\pm 1^{\circ}\text{C}$  and  $4\pm 1^{\circ}\text{C}$  are obtained at 300 and 1000mm depth respectively.

Maintain this temperature for 2 weeks.

Lower the ground level temperature to  $-13\pm 1^{\circ}\text{C}$  and maintain for 3 days.

Remove the freezer unit and inspect the box for signs of freezing.

The box is required to show no signs of deterioration due to low temperatures. Water is to be passed through the boundary box and the meter at a minimum pressure of 1 bar. The meter is required to operate correctly and there should be no evidence of leakage.

### B.3 TEST REPORT

The test report shall include:

- (a) The full identification of the specimens,
- (b) Description of fitting assembly,
- (c) Test conditions,
- (d) Observations. The test shall be recorded as pass or fail,
- (e) The date of the test.

## APPENDIX C - HYDRAULIC PERFORMANCE HEAD LOSS: TYPE TEST

This test, based on BS 5728: Part 3 for measuring flow in single meters, can be used to assess the hydraulic efficiency of a boundary box.

### C.1 APPARATUS

The apparatus shall be as described in BS 5728: Part 3.

**A pump** capable of providing hydraulic flow-rates between 5 and 60 litres/minute.

**Pressure gauges** which are capable of connection to the inlet and outlet pipes as specified in BS 5728.

**Service pipe**, of a size and quality for which the unit is designed, to which the inlet/outlet connections of

the boundary box are made and on which the pressure tapings are made.

### C.2 PROCEDURE

The test shall be conducted in accordance with the procedure described in BS 5728: Part 3 using suitably accredited equipment. The static differential pressure ( $\Delta P_2$ ) is measured at the selected flow rate between the pressure tapings of the measuring section assembled with the boundary box. The measurements are repeated for the same pipe at the same flow-rate in the absence of the boundary box ( $\Delta P_1$ ).

The actual headloss due to the fitting is given by:

$$\Delta P = \Delta P_2 - \Delta P_1$$

### C.3 TEST REPORT

The test report shall include:

- (a) The full identification of the specimens and make of meter used,
- (b) Description of fitting assembly including meter,
- (c) Test conditions (including flow rates),
- (d) The headloss due to the boundary box in metres,
- (e) The date of the test.

## APPENDIX D – PRESSURE RELEASE MECHANISM: TYPE TEST

This test can be used to assess the ability of a Class 1 boundary box to release excessive pressures in a safe manner.

### D.1 APPARATUS

A **suitable pressure source** capable of being connected to the body of the boundary box and holding the specified test pressure to an accuracy of  $\pm 2\%$ .

A **pressure gauge** for checking the applied pressure.

### D.2 PROCEDURE

For the purpose of this test, it is acceptable to remove the meter, connect the water supply to the inlet and

blank off the outlet. Provision for a suitable pressure inlet point shall be made in the body of the box.

The boundary box is to be assembled in the vertical position. Apply an hydraulic pressure, increasing the level from atmospheric pressure to 0.2 bar gauge over a period of 5 minutes.

The test shall be declared satisfactory if:

- (a) pressure release occurs at a pressure not exceeding 0.2 bar,
- and
- (b) pressure release occurs in a safe manner.

### **D.3 TEST REPORT**

The test report shall include:

- (a) The full identification of the specimens,
- (b) Description of fitting assembly,
- (c) Test conditions,
- (d) Observations and results,
- (e) The date of the test.

## **APPENDIX E - HYDRAULIC PRESSURE: TYPE TEST/QUALITY CONTROL TEST**

This test, based on BS 5114 (ISO 3458/3459) for assembled joints between fittings and polyethylene pressure pipes, can be used to assess the leakproofness of a boundary box when subjected to (a) internal hydrostatic pressure and (b) internal vacuum.

### **E.1 APPARATUS**

A suitable pressure source capable of being connected to the assembled test specimen and holding the specified test pressure to an accuracy of  $\pm 2\%$ .

A pressure gauge for checking the applied pressure.

### **E.2 PROCEDURE**

The boundary box assembly shall include an approved meter. The dimensions of the connecting threads shall be checked for compliance with BS 5728.

The inlet of the boundary box shall be connected to the pressure source. The outlet shall be sealed off.

### **E.2.1 Quality control**

Apply an internal hydrostatic pressure of 16 bar for a minimum of 5 minutes and inspect the assembly for any sign of leakage. The test shall be declared satisfactory if no leakage occurs during the test.

### **E.2.2 Type test**

The internal vacuum test shall be carried out at two levels of pressure difference between the external and internal pressures, of 0.01 and 0.08MPa (0.1 and 0.8 bar). Apply the initial pressure for 1 hour, increase the pressure differential and hold for a further 1 hour.

The test shall be declared satisfactory if no leakage occurs during the test.

### **E.3 TEST REPORT**

The test report shall include:

- (a) The full identification of the specimens,
- (b) Description of fitting assembly,
- (c) Test conditions,
- (d) Observations and results,
- (e) The date of the test.

## APPENDIX F - WATER TIGHTNESS: TYPE/QUALITY CONTROL TESTS

This test can be used to assess the water tightness of Class 1 boxes.

### F.1 APPARATUS

**Water tank** capable of submerging the boundary box completely.

**A method** of holding the box at the specified level in the tank.

### F.2 PROCEDURE

The boundary box shall be assembled in the vertical position. For the purpose of this test, it is acceptable to replace the meter with a meter blanking plate. The pipework and manifold should be free from water and the inlet and outlet sealed to prevent contamination.

#### Type test:

The complete assembly shall be submerged in water at ambient temperature for 30 days.

#### Quality control test:

The complete assembly shall be submerged in water at ambient temperature. The assembly shall be monitored for signs of leakage i.e. air bubbles.

The box is required to show no signs of leakage into the box in either test.

### F.3 TEST REPORT

The test report shall include:

- (a) The full identification of the specimens,
- (b) Description of fitting assembly,
- (c) Test conditions,
- (d) Observations,
- (e) The date of the test.

## APPENDIX G - INSULATION MATERIAL DURABILITY: TYPE TEST

This test can be used to assess the durability of the insulation material, where supplied.

### G.1 PROCEDURE

The insulation material shall be withdrawn from, and effectively repositioned within, the box and the procedure repeated for a minimum of 500 cycles.

The insulation material is required to show no signs of undue deformation or degradation.

The insulation material shall be weighed and then completely submerged in water for 15 minutes. The material shall be re-weighed following removal from the water. The difference between the two readings shall not exceed 10% of the original (dry) weight.

### G.2 TEST REPORT

The test report shall include:

- (a) The full identification of the specimen.
- (b) Test conditions.
- (c) Observations. The results shall be recorded as pass or fail.
- (d) The date of the test.