WATER INDUSTRY SPECIFICATION

WIS 4-32-17

August 2001: Issue 2

(Page 1 of 26)

ISSN 1353-2510

UK Water Industry

POLYETHYLENE PRESSURE PIPES FOR PRESSURISED WATER SUPPLY AND SEWERAGE DUTIES

FOREWORD

This document is the specification for polyethylene pressure pipes for pressurised water supply and sewerage duties. This second edition incorporates minor revisions to facilitate third party assessment of conformity.

It has been prepared by Pipeline Developments Ltd. under the direction of the UK Water Industry's Standards Horizontal Group in consultation with the Water Industry and manufacturers. It harmonises the performance requirements previously specified in, and supersedes, WISs 4-32-03, 4-32-09 and 4-32-13. Existing test methods from these WISs have been used wherever possible.

The requirements of the British Standards BS 6572 and BS 6730 are also accommodated as are the requirements of European Standards prEN 12201 and prEN 13244. Note that, it is not intended that this Water Industry Specification should supersede BS 6572 and BS 6730 in purchasing contracts

It should be noted that this document adopts the ISO classification of PE materials. PE100 is now used to describe HPPE grades. PE80 is now used to describe MDPE

It is intended that an Information and Guidance Note describing the relationship between the properties which are required of PE pipes and the design philosophy currently used by the UK Water Industry will be prepared to complement this Specification. This IGN will be numbered 4-32-18. Clauses in which this document is referenced are shown in italics.

Compliance with this specification does not itself confer immunity from legal obligations.

This specification does not purport to included all the necessary provisions of a contract. Users of this

specification are responsible for its correct application. Reference to British Standard, Water Industry Specification or any other specification applies equally to any equivalent specification.

This specification includes the use of substances and/or procedures that may be injurious to health if adequate precautions are not taken. It refers only to technical suitability and does not absolve the user from legal obligations relating to health and safety at any stage.

It has been assumed in the drafting of this specification that the execution of its provisions is entrusted to appropriately qualified and experienced people.

Information contained in this specification is given in good faith. Neither UK Water Industry Research Ltd, Water UK, WRc plc nor Pipeline Developments Ltd can accept any responsibility for actions taken by others as a result.

Technical enquiries should be directed to: WRc plc, Frankland Road, Blagrove, Swindon, Wilts, SN5 8YF

Further copies from:

WRc, Frankland Road, Blagrove, Swindon, Wilts, SN5 8YF
Tel: +44 (0) 1793 865138/069/012 Fax: +44 1793 865001

UK WIR © 2001

CONTENTS

1. SCOPE
2. PREFERRED PRESSURE CLASSES AND SIZES
3. CLASSIFICATIONS
4. TESTING - STATUS
5. MATERIALS PROPERTIES (DETERMINED BY MATERIALS SUPPLIER)
6. MATERIALS PROPERTIES (DETERMINED BY PIPE MANUFACTURER)
7. DIMENSIONS
8. TYPE TESTS
9. BATCH RELEASE TESTS
10. MARKING
11. SUPPLY OF STRAIGHT AND COILED PIPES
12. REFERENCES

APPENDIX A – CHARPY IMPACT TESTING METHODOLOGY

APPENDIX B – METHOD FOR THE DETERMINATION OF SLOW CRACK GROWTH RESISTANCE

APPENDIX C – REQUIREMENTS FOR POLYETHYLENE PIPE, SUPPLIED AS COILS OR ON DRUMS

1. SCOPE

This document specifies the requirements for PE pipes for the following duties:

- Blue pipes for potable water supply for use below ground in diameters 20 mm to 1600 mm.
- Blue pipes with brown stripes (to indicate an external 'skin' of a different polymer – to provide resistance to scoring, use for contaminated land etc.) in diameters 20 mm to 250 mm (or above-as demand dictates).
- Black pipes for above ground use for potable water supply in diameters 20 mm to 1600 mm.
- Black pipes for sewerage and general purpose duties in diameters 20 mm to 1600 mm.
- Black pipes with brown stripes (to indicate the presence of an external 'skin' of a different polymer – to provide resistance to scoring) in diameters 20 mm to 250 mm (or above-as demand dictates).
- Black pipes with green stripes for grey water in diameters 20 mm to 1600 mm.
- Coiled pipe in diameter range 20 mm to 180 mm.

The requirements of this specification include materials, dimensions, effect on water quality and marking as well as physical and mechanical properties.

NOTE 1: Grey water transmission includes the conveyance of raw water prior to treatment.

NOTE 2: Blue pipe may be used above ground only if protected against UV light.

For all pressure duties there are no differences in mechanical properties required for water supply and other applications.

PE pipes used with protective 'skins' shall meet all the requirements of this specification. However, any additional properties of 'skinned' pipes are outside the scope of this document.

2 PREFERRED PRESSURE CLASSES AND SIZES

PE pipes shall be standardised in three size ranges:

Range 1: 20 mm to 63 mm - Pipe will be PN 12.5 PE80

Range 2: 75 mm to 315 mm

Range 3: 355 mm to 1600 mm

NOTE: See clause 3.2 for pressure classes relevant to Ranges 2 and 3.

3. CLASSIFICATIONS

3.1 Material Classification

3.1.1 This specification requires that the materials supplier shall be able to verify using rapid crack propagation test data that the design pressures for large diameter pipes are not compromised. This shall be in addition to requirements for the minimum MRS values.

NOTE: Where the supplier does not have pressure pipe data for a PE 80 material indicating full resistance to RCP, but instead only has notched impact toughness data (clause 5.3.5) as a measure of RCP resistance, the re-rated pressure should be determined in accordance with criteria given in Information and Guidance Note (IGN) 4-32-18 on the 'Choice of Pressure Ratings for PE Pipe for Water Supply and Sewerage Duties'.

3.1.2 Pipes shall meet the appropriate long-term stress crack resistance properties as specified below.

a) **PE 100** shall have an MRS of 10 MPa at 50 years at 20°C, full RCP resistance, and >1000 h long term crack resistance (see 5.3.3).

b) **PE 80** shall have an MRS of 8 MPa at 50 years at 20°C, RCP resistance in accordance with 4.3.4, and ≥ 1000 h long term crack resistance (see 5.3.3).

NOTE: In line with CEN and ISO recommendations, the Overall Service (Design) Coefficient C will be 1.25 in accordance with BS EN ISO 12162.

3.2 Pressure Classification

3.2.1 For 20 mm to 63 mm diameter pipes (range 1, see Clause 2): all pipes shall be supplied as SDR11.

NOTE: This formally equates to a pressure class of PN12.5. It is recognised that suppliers will wish to supply small bore pipes which are marked to the requirements of BS 6572 and BS 6730 which use a PN12 rating for SDR11. This does not imply any de-rating, in practice, the pipe will still sustain 12.5 bar pressures.

3.2.2 For 75 mm to 315 mm diameter pipes (range 2, see Clause 2): the preferred pressure ratings for different SDRs are given in Table 1.

3.2.3 For sizes above 315 mm (range 3, see clause 2): the pressure ratings are given in Table 1 for those materials that meet the full RCP requirements as defined in Table 4.

SDR	PE 80	PE 100
11	PN12.5	PN16
17	PN8	PN10
26	PN5	PN6

Table 1: Pressure ratings for different materials

NOTE 1: Where pipe made from PE 80 material only meets either the reduced RCP requirements in Table 4 of this specification or the notched sample impact toughness requirements in 5.3.5, the pressure rating may be reduced by a design factor (f) as given in IGN 4-32-18. The pipe marking should include an agreed reference to indicate this (see Clause 10 of this specification).

NOTE 2: Other SDRs may be used for special applications. Advice is given in IGN 4-32-18.

4. TESTING – STATUS

4.1 General

Type and Batch Release tests are carried out by the raw material supplier and the pipe manufacturer.

For Type Tests the extreme diameters in each size group (see clause 2) and the largest diameter manufactured shall be tested unless otherwise stated in the referring text or Appendices.

TEST	Type Test	BRT	Clause
• Black compound			
Carbon black content	/	/	5.2.3c
Carbon black dispersion	/	/	5.2.4
• Blue compound			
Colour	/	/	5.2.3 a)
Dispersion	/	/	5.2.4
Weathering	/		5.4
• All compounds			
Density	/	/	5.2.7
Long term MRS at 20°C	/		5.3.1
OIT	/	/	5.2.6
MFR	/	/	5.2.5
Moisture		/	5.6.1
General properties	/		5.3.2
Long term Stress Crack Resistance at 80°C: on notched pipe	/		5.3.3
Resistance to fracture by impact (Gc)	/		5.3.5
RCP (Full Scale Test)	/		5.3.4
Welding Characteristics	/		5.5

Table 2: Raw Material Suppliers Tests

TEST	Type Test	BRT	Clause
Dimensions		/	7
OIT		/	9.2.3
Tensile yield stress		/	9.2.2
Elongation		/	9.2.2
MFR Change ¹		/	9.2.4
Appearance		/	9.2.5
Long term hydrostatic at 20°C (Cross checks)	/		8.2
Long term hydrostatic at 20°C (Squeezed pipe)	/		8.3
Short term Stress Crack Resistance ² or Notched C Ring (> 225 mm)		/	9.3.2.1 or 9.3.2.2
Long term Stress Crack Resistance at 80°C: on notched pipe	/		8.4
Welding of coiled pipe	/		8.5
Charpy Impact Gc (PE-80 materials for sizes >315 mm & large quantities)		/	9.3.3
Water Quality	/		6.1
<i>Note 1: Only when reprocessed material used</i>			
<i>Note 2: Size ranges 2 and 3</i>			

Table 3: Pipe Manufacturer's Tests

5. MATERIALS PROPERTIES (DETERMINED BY MATERIALS SUPPLIER)

5.1 Materials

The physical and mechanical properties of the raw material and tests (Type Tests) described in sections 5.2 and 5.3 shall form the basis of a technical file or dossier for the material.

The tests listed in section 5.6 are Batch Release Tests and shall form the basis of a supply agreement between the pipe manufacturer and the materials supplier.

5.2 Physical Properties

5.2.1 Base polymer

The base polymer used for the manufacture of PE 80 compounds shall have a reference density in the range: $930 < \rho < 940 \text{ kg/m}^3$.

5.2.2 Compound composition

The compound from which pipes are produced shall be made by adding to the base polymer only those additives antioxidants, pigment, carbon black, UV stabilisers, etc. that are necessary for the manufacture and end use of the products conforming to the requirements of this standard. All additives shall be uniformly dispersed.

5.2.3 Colour

a) The colour for polyethylene pipe for underground potable water applications shall be (light) blue for PE80 within the range 18E51 to 18E53 of BS 5252 and (dark) blue for PE100 within the range 20D44 to 20D45 or 20E53 to 20E56.

NOTE: The colour of the skin on skinned pipe shall comply with these requirements.

b) The colour of the pipe for above ground applications, sewerage and general purpose water shall be black. The carbon black used shall have a primary particle size of 10 nm to 25 nm.

c) Carbon black content shall be 2% to 2.5% when measured according to ISO 6964.

5.2.4 Pigment Dispersion

The dispersion of pigment shall be uniform, and meet \leq grade 3 when measured in accordance with ISO 13949 using the compression method. For carbon black dispersion, ISO 11420 shall be used with the same requirements.

5.2.5 Melt Mass Flow Rate (MFR)

This shall be determined by the method given in ISO 1133 (condition T). Variations shall be within the range $\pm 20\%$ of the nominal value quoted by the material supplier.

5.2.6 OIT

The material shall meet a requirement of ≥ 20 minutes when tested at 200 °C according to ISO TR 10837. Tests may be carried out at 210 °C or higher providing there is a clear correlation to the results at 200 °C. In the case of dispute the reference temperature shall be 200 °C.

5.2.7 Density

The density of the final coloured compound, shall be determined in accordance with ISO 1183 Part 1. This shall apply for both blue and black compounds.

5.3 Mechanical Properties

5.3.1 Determination of Long Term MRS: The MRS of the material shall be determined at 20 °C, 50 years using the ISO TR 9080 method of analysis in order to classify the material either PE 80 or PE 100 from the 97.5% LCL in accordance with BS EN ISO 12162.

The lifetime at a stress of 1.2 times MRS shall be declared to indicate a safe time for pressure tests during mains commissioning.

5.3.2 General Properties for Installation and Design

For the purposes of design against short term loading and long-term creep deformation at 20 °C, the supplier of the raw material shall provide the following information to both the pipe supplier and purchaser (if requested).

(a) **Stress-Strain Response:** The tensile yield stress, yield strain and failure strain of the polymer. Tests shall be conducted at a nominal strain rate of 0.2/sec.

(b) **Short Term Surge Pressure Resistance:** The value of the short term burst stress of a notched pipe (of size > 90 mm) made from the compound shall be given (notching to 10% of wall by method given in BS EN ISO 13479). The pipe shall be pressurised to either give failure or attainment of at least 2.5 times the pressure rating (PN) at a loading rate of 8 bar/sec – in accordance with IGN 4-37-02.

5.3.3 Long Term 80°C Stress Crack Resistance on Notched Pipe

When tested in accordance with BS EN ISO 13479 (Notched Pipe Test), the pipe shall not fail within 1000h when pressurised at 9.2 bar (PE 100) or 8.0 bar (PE 80), as appropriate.

The test shall be carried out on 110 mm, 125 mm or 180 mm SDR11 pipe.

5.3.4 Resistance to Rapid Crack Propagation

To demonstrate resistance to rapid crack propagation (RCP), the pipe shall be tested in accordance with and meet the requirements in Table 4.

Resistance to RCP 1.2	Requirements	Conditions	Material	Internal Pressure	Test Method
250 mm SDR11	ARREST: defined in EN13477 (S4) EN13478 (FST)	Temp $\leq 3^{\circ}$ C Contents:			
	Full resistance	100% air	PE 100 ¹ PE 80 ¹	10 bar 8 bar	EN 13477 EN 13477
500m m SDR11	Full resistance	100% air	PE 80 ² PE 80 ²	8.5 bar 14 bar	BS EN ISO 13478
	Reduced resistance	100% air			
	Reduced resistance	5% Air 95% Water	PE 100 ¹ PE 80 ¹	24 bar 20 bar	BS EN ISO 13478
	Full resistance Full resistance	100% air 100% air			BS EN ISO 13478
<p>Note1: If these requirements are met, the material is qualified for consistent ratings of all ranges of pipe produced in accordance with the scope of this document.</p> <p>Note2: If only these reduced requirements are met, the PE 80 ratings should be reduced for Range 3 sizes and SDRs as shown in Table 2 of IGN 4-32-18.</p>					

Table 4: RCP Requirements for PE Materials

5.3.5 Resistance of Notched Samples to Fracture by Impact

When tested in accordance with Appendix A, the critical strain energy release rate (Gc) of samples shall be greater than values given in Table 5.

NOTE: To assess the performance of the raw material, the test may be carried out on samples machined from the bore of pipe of an appropriate thickness or compression moulded sheet.

Material MRS (kg/cm ²)	Gc at 23°C 12mm*12mm (kJ/m ²)	Gc at 0°C 2mm*10mm (kJ/m ²)
80	8	14
100	12	60

Table 5: Impact toughness requirements

A PE 80 grade pipe with reduced pressure ratings for Range 3 (i.e. >315 mm) shall only be acceptable if:

- a) the raw material supplier declares that there is no known history of RCP failures in service, and
- b) the impact toughness requirements given in Table 5 are met.

5.4 Weathering Resistance

To demonstrate satisfactory weathering resistance, the supplier shall expose pipe of size ≥ 90 mm (SDR11) to cumulative solar radiation >3.5 GJ/m² (EN1056, ISO 4607).

After exposure, the test pieces shall meet the requirements of 9.2.2 and 9.3.2 of this specification.

When tested in accordance with 9.2.3 of this specification, the OIT of the exposed surface, after scraping less than 0.4 mm of the surface shall be >10 min.

NOTE: Skinned pipe shall comply with these requirements without the skin.

5.5 Welding Characteristics

5.5.1 Materials

Only those materials which may be welded in accordance with WIS 4-32-08 (for butt fusion) or equivalent shall be used to produce pipe to this specification.

5.5.2 Butt fusion (standard)

Sample welds shall be made using both the single and dual pressure conditions in WIS 4-32-08, as appropriate to the pipe wall thickness.

When tested in accordance with Appendix D of this specification, all samples shall fail in a ductile manner.

5.5.3 Butt fusion (offset)

Sample welds shall be made as described in 5.5.2, with a radial offset of at least 10% of wall thickness.

Hydrostatic stress rupture tests shall be carried out at 80 °C and at a stress level of 4.0 MPa (PE 80) or 5.0 MPa (PE 100) in accordance with ISO 1167, the time to failure shall not be less than 1000 hours.

5.5.4 Fusion Compatibility

Unless otherwise declared by the material supplier, all materials having a nominal MFR 190/5 within the range 0.2 g/10 min to 1.4 g/10 min shall be considered compatible for fusion to each other.

NOTE: Guidance on butt fusion welding together of PE 80 and PE 100 materials should be sought from the manufacturer.

5.6 Batch Release Tests

The supplier is required to carry out basic tests (specified below in 5.6.1) on a representative sample from the batch supplied.

The supplier shall operate a quality system conforming to BS EN ISO 9001/9002 as applicable. This shall include a quality plan whereby details and results for each test in clause 5.6.1 for each material composition shall be made available to the purchaser or his representative on request.

5.6.1 Test requirements:

The tests listed in clauses 5.2.3 a) and c), 5.2.4, 5.2.5, 5.2.6, and 5.2.7

In addition:

The residual moisture content shall be < 300 mg/kg measured by the method given in EN 12118 or ISO 760.

5.7 Processing Information

The materials supplier shall provide the pipe manufacturer with all necessary information to allow the compound to be processed into pipe to conform to this specification. This shall include at least the requirements in 5.2.2 and 5.2.3.

6. MATERIALS PROPERTIES – (DETERMINED BY PIPE MANUFACTURER)

6.1 Water Quality Approval

It is the responsibility of the pipe manufacturer to secure approval that pipe made from any compound offered for potable/raw water transmission has approval from the Drinking Water Inspectorate (DWI). Changes shall not be made to any approved compound unless they have been ratified with the DWI.

All materials in contact with, or likely to come into contact with, water for public supply shall be introduced in compliance with the requirements of Regulation 25 of the Water Supply (Water Quality) Regulations 1989 or Water Supply (Water Quality) (Scotland) Regulations 1990 or Regulation 24 of the Water Supply Regulations (Northern Ireland) 1994, as appropriate.

Whenever DWI regulations change, it is the supplier's responsibility to ensure conformity with any new requirements

Regulation 25 (1) (a) (24 in N. Ireland) approval is mandatory. This applies only to products used by water companies in the treatment and distribution of public water supplies: it does not apply to use of fixtures and fittings on consumers' premises. Approval under the Water Regulations Advisory Scheme is also mandatory.

For water pipes, it is permissible to only use compounds with stabilisers, antioxidants or other additives which do not impart unacceptable taste and odour to the water (e.g. as listed in Table 7 of BS 3412:1992), x 6,6 - diterbutyl - 4, 4 - thiodi-m-cresol. shall not be used.

6.2 Rework

Clean reprocessable material generated from a manufacturer's own production of pipes conforming to this specification may be used if it is derived from the same compound as used for the relevant production. Other reprocessed material shall not be used.

7. DIMENSIONS

7.1 Diameter and wall thickness

Pipe shall conform to the outside diameter and wall thickness in accordance with ISO 161-1 (diameters), ISO 4065 (universal wall thicknesses) and ISO 11922-1 (tolerances) for the nominal sizes given in section 2.1 and SDRs specified in Table 1.

The outside diameter shall be measured according to BS 2782, Method 1101A, at a distance of at least one diameter from the end of the pipe. The wall thickness of any point around the circumference shall be measured according to BS 2782, Method 1101A, or by an alternative method of at least equivalent accuracy.

Measurements of all dimensions shall be related to reference dimensions at $23^{\circ}\text{C} \pm 2^{\circ}\text{C}$.

The mean outside diameter of the pipe at a distance from its end of $< 0.1 \times$ the diameter shall not be less

than 98% of the diameter measured at least one pipe diameter from the pipe end.

The ovality of pipes up to including nominal size 250 mm shall not exceed 0.02. The ovality of pipes greater than 250 mm shall not exceed 0.035.

NOTE 1: A list of all pipe dimensions is given in Table 6.

NOTE 2: Ovality is defined as: (maximum individual pipe diameter minus the minimum individual pipe diameter) divided by the mean pipe diameter.

SUPERCEDED

Min OD (mm)	Max OD (mm)	Max Ovality (mm)	Wall Thicknesses for pipe series					
			SDR 11		SDR 17		SDR 26	
			min	max	min	max	min	max
20	20.3	1.2	2.3	2.6	-	-	-	-
25	25.3	1.2	2.3	2.7	-	-	-	-
32	32.3	1.3	3.0	3.4	-	-	-	-
40	40.4	1.4	3.7	4.2	-	-	-	-
50	50.4	1.4	4.6	5.2	-	-	-	-
63	63.4	1.5	5.8	6.5	-	-	-	-
75	75.5	1.6	6.8	7.6	-	-	-	-
90	90.6	1.8	8.2	9.2	5.4	6.1	-	-
110	110.6	2.2	10.0	11.1	6.6	7.4	4.2	4.8
125	125.6	2.5	11.4	12.7	7.4	8.3	4.8	5.4
140	140.9	2.8	12.7	14.1	8.3	9.3	5.4	6.1
160	161.0	3.2	14.6	16.2	9.5	10.6	6.2	7.0
180	181.1	3.6	16.4	18.2	10.7	11.9	6.9	7.7
200	201.2	4.0	18.2	20.2	11.9	13.2	7.7	8.6
225	226.4	4.5	20.5	22.7	13.4	14.9	8.6	9.6
250	251.5	5.0	22.7	25.1	14.8	16.4	9.6	10.7
280	281.7	5.8	25.4	28.1	16.6	18.4	10.7	11.9
315	316.9	6.6	28.6	31.6	18.7	20.7	12.1	13.5
355	357.2	7.6	32.2	35.6	21.1	23.4	13.6	15.1
400	402.4	8.6	36.3	40.1	23.7	26.2	15.3	17.0
450	452.7	9.6	40.9	45.1	26.7	29.5	17.2	19.1
500	503.0	10.6	45.4	50.1	29.7	32.8	19.1	21.2
560	563.4	11.6	50.8	56.0	33.2	36.7	21.4	23.7
630	633.8	12.6	57.2	63.1	37.4	41.3	24.1	26.7
710	714.0	13.6	-	-	42.1	46.5	27.2	30.1
800	805.0	14.6	-	-	47.4	52.3	30.6	33.8
900	905.0	15.6	-	-	53.3	58.8	34.4	38.3
1000	1005.0	16.6	-	-	59.3	65.4	38.2	42.2
1200	1206.0	18.6	-	-	-	-	45.9	50.6
1400	1406.0	20.6	-	-	-	-	53.5	59
1600	1606.0	22.6	-	-	-	-	61.2	67.5

Table 6: Pipe Dimensions

7.2 Cut end tolerance

The ends of the pipe shall be cut cleanly and square to within the tolerances given in Table 7.

Nominal Pipe Diameter (mm)	Maximum tolerance (mm)
20	2
25	2
32	2
40	2
50	2
63	2
75	2
90	2
125	3
140	3
160	3
180	4
225 < 315	5
355 < 500	7
560 < 1000	10
1000 < 1600	15

Table 7: Cut End Tolerances

7.3 Length

Standard pipe lengths are 6 m, 12 m and 18 m. Other lengths should be agreed by negotiation.

7.4 Coil Dimensions

Polyethylene pipes in the size range 75 mm to 180 mm, supplied as coils or on drums, shall be produced in accordance with the requirements of Appendix C of this specification.

Coils are normally supplied in 25 m, 50 m, 100 m, and 150 m lengths dependent on diameter. Overall dimensions of coils or pipe on drums shall be as shown in Table 8.

Nominal Pipe Diameter (mm)	Minimum Internal Coil Diameter (m)	
	SDR 11	SDR 17
20	0.6	n/a
25	0.6	n/a
32	0.7	n/a
40	1.0	n/a
50	1.0	n/a
63	1.3	n/a
75	1.5	2.2
90	1.8	2.5
110	2.0	2.5
125	2.5	2.5
160	2.5	2.5
180	3.0	3.0

Table 8: Coil Dimensions

After uncoiling, the ovality (as defined in 7.1 Note 2) of any pipe section shall be less than 12% and 6% for SDR17 and SDR11 product respectively.

Polyethylene pipes in the size range 90 to 180, supplied as coils or on drums, shall be produced in accordance with the requirements of Appendix C. If required, equipment for re-rounding and/or straightening the ends of coils shall be used, particularly on nominal size 180.

8. TYPE TESTS

8.1 General Requirements

The following tests in this section are designed to demonstrate that the pipe produced by the manufacturer has the same long term properties as the basic material compound. They are not required to be performed on each batch of pipe.

8.2 Long-term hydrostatic strength at 20°C

When tested in accordance with the method described in ISO 1167, the failure times of 3 test pieces (one from each manufactured range) shall be greater than the failure times from the LCL line relevant to the stresses at 100, 1000 and 5000h from data generated by the material supplier to determine the MRS classification of the material in accordance with ISO/TR 9080.

NOTE: Manufacturers can claim provisional acceptance with the requirements of this clause by completing the tests up to 1000 h providing the test piece relevant to 5,000 h is in progress.

8.3 Pipe subjected to Squeeze-Off

When squeezed-off in accordance with BS EN 12106: 1998, the time to failure in a hydrostatic stress rupture test at a stress level of 4.6 MPa (PE 80) and 5.5 MPa (PE 100) of a sample of 180 mm SDR11 pipe shall not be less than 165 h.

8.4 Long Term 80°C Stress Crack Resistance on Notched Pipe

Pipe suppliers shall determine long term stress crack growth data on pipe from their own production on all materials used.

The requirements of 5.3.3 shall be met.

NOTE: For skinned pipe, the skin is ignored for the purposes of this test, i.e. the thickness of the remaining ligament after notching specified in BS EN ISO 13479 apply.

8.5 Welding of Coiled Pipe

Using standard industry equipment, the pipe manufacturer shall demonstrate that coiled pipe can be satisfactorily re-rounded to allow jointing by both butt fusion and electrofusion. The pipe section for testing shall be cut from the part of the coil with the smallest radius.

Compliance with this requirement shall be demonstrated by a type test using PE 100 160 mm or 180 mm SDR17 coiled pipe. Butt fusion joints made to WIS 4-32-08 shall satisfy the requirements of clause 5.5.2 within this specification. Electrofusion coupler joints made and tested according to Appendix B of WIS 4-32-14 March 1995, shall satisfy the toughness requirements in clause 7.8 of that specification.

NOTE: This pipe test does not remove the need for fittings suppliers to demonstrate the performance of their electrofusion couplers against relevant Water Industry specifications.

9. BATCH RELEASE TESTS**9.1 General Requirements**

Before releasing any batch of pipe, the supplier is required to carry out basic tests (specified below) on

representative pipe samples from the batch to be supplied

The manufacturers shall operate a quality system conforming to BS EN ISO 9001/9002 as applicable. This shall include a quality plan whereby details and results for each test in clause 8 for each material composition shall be made available to the purchaser or his representative on request.

9.2 Batch Release Tests on pipes in all size ranges

9.2.1 For all size ranges, the manufacturer shall employ a quality control system requiring regular checking of the following.

9.2.2 Tensile Properties: Tests shall be carried out in accordance with ISO 6259 (Parts 1 & 3) using the specified test speeds. The value of yield stress (σ_y) and elongation at break shall not be less than the values given in Table 9.

Property	PE 80	PE 100
Tensile Strength	≥ 15 MPa	≥ 19 MPa
Elongation	≥ 350%	≥ 350%

Table 9: Tensile properties

9.2.3 Oxidation induction time: The material shall meet a requirement of ≥ 20 minutes when tested at 200°C according to ISO TR 10837. Tests may be carried out at 210°C or higher providing there is a clear correlation to the results at 200°C. In the case of dispute the reference temperature shall be 200°C.

9.2.4 MFR Change: When reprocessed material is used, the MFR shall not change on samples taken from the product by more than 20% from the range of the virgin compound supplied.

9.2.5 Appearance

When viewed without magnification, the internal and external surfaces of the pipe shall be smooth, clean and free from scoring, cavities and other surface defects which may affect pipe performance.

9.3 Additional Batch Release Tests on pipes in size ranges 2 and 3

9.3.1 The manufacturer shall employ a quality system requiring regular checking of the short term stress crack resistance by the Notched Pipe Test.

The Notched C Ring test is an alternative option to the Notched Pipe Test for pipe of diameter > 225 mm.

The Charpy Impact Toughness measurement shall be made on pipe of diameter > 315 mm when the production volume exceeds the stated figures in clause 9.3.3.

9.3.2 Short Term 80°C Stress Crack Resistance

9.3.2.1 Notched Pipe Test: For batch release of pipe in size ranges 2 and 3 only the pipe supplier shall carry out 80°C/165 h control point tests on notched pipe in accordance with BS EN ISO 13479. Values for appropriate test conditions for different pipe SDRs are given in Table 10.

NOTE 1: One pipe specimen is deemed sufficient for this purpose.

NOTE 2: The batch may be released earlier by agreement with the purchaser based on historical conformance with the test requirements.

NOTE 3: For skinned pipe, the skin is ignored for the purposes of this test, i.e. the remaining ligaments after notching specified in BS EN ISO 13479 apply.

SDR	Test Pressure PE 80 & PE 100
11	9.2 bar
17	5.75 bar
26	3.68 bar

Table 10: Test Pressures for 80°C Stress Crack Resistance Test

9.3.2.2 Notched C Ring: Where there are time constraints in completing the batch release test requirements set out in clause 9.3.2.1 on larger diameter pipes (>225 mm SDR11), the 20°C stress crack resistance may be determined using the C Ring procedure in Appendix B.

The load level shall be calculated to apply stresses to cause failure at 1 hr. Where samples have not failed after 10 hr, the test may be discontinued at the supplier's discretion.

NOTE 2: To ease assessment of the 1h control, samples shall be loaded at different stresses to establish a regression line to compare with pressurised pipe regression data.

The result at the test stress shall be greater than the 95% upper confidence limit line generated from

pressure tests. The failure shall be via ductile tearing rather than unstable, brittle cracking.

9.3.3 Charpy Impact Toughness

For PE 80 materials where pressure rating reduction is applied for sizes > 315 mm, the impact toughness shall be determined whenever a production run producing total pipe in excess of 2 km or 100 tonnes weight of pipe is executed.

The test shall be carried out in accordance with Appendix A of this specification at both 0°C and 23°C. Samples shall be cut from the axial direction and taken from a region as close to the bore as possible. The toughness (Gc), shall meet the requirements given in Table 5.

10. MARKING

The marking of pipe shall remain legible under normal handling, storage and installation procedures. No method of marking shall prejudice the performance of the pipe when tested to the requirements of this specification. The marking shall show the following:

- The manufacturer's identification, the polymer classification (e.g. PE 80, or PE 100) together with a code identifying the basic raw material source.
- The number of this specification.
- The nominal size and SDR.
- Continuous pressure rating at 20°C (Either PN'X' or 'X'bar is acceptable).

Values shall conform to those in Table 1 for all pipes that carry the full design stress.

NOTE: Where there has been pressure rating reduction applied for PE 80 materials in Range 3 (see 2.2.3), the marking should be agreed between client and supplier) to indicate that the design stress is reduced.

- Along one strip only- the manufacturing codes to identify the production line, date and production shift.
- For pipe intended for potable water supply the word "WATER" shall appear 3 times/metre.
- For pipe intended for grey water supply the words "GREY H2O" shall appear 3 times/metre.
- For sewage/drainage pipe, the words "WASTE WATER" shall appear 3 times/metre. For grey water

transport, pipe shall be black with green stripes on quadrants. Stripes shall be clearly visible - typically in the range 8 mm to 16 mm wide for sizes 90 mm to 355mm.

i) All coils of pipe > 63 mm diameter shall have the lead and trailing ends clearly marked with the words "START" and "END" - indicating which bands are to be first cut.

All pipes shall be marked at intervals not greater than 1 m along two strips on opposite sides of the pipe for diameters > 90 mm. For diameters < 90 mm marking along one strip only is sufficient. The marking shall be printed in a suitable shade of the following colours:

SDR 11 Black (blue pipe) : White (black pipe): SDR
17 Red : SDR 26 Yellow

The height of characters shall be greater than 3 mm for pipe sizes less than 125 mm and greater than 5 mm for sizes \geq 125 mm.

11. SUPPLY OF STRAIGHT AND COILED PIPE

11.1 Supply of Straight Pipes

Whilst under the manufacturer's control, the pipes shall be stacked/stored in such a way to minimise dimensional changes, scratches and the effect of weather. The pipe shall also be protected from contamination.

Straight lengths of pipe shall be supplied in crates that are constructed to minimise distortion of, or damage to, the pipes during transit or storage.

When requested by the customer, all pipe intended for potable water supply should be provided with end closures to prevent ingress of contaminants. All swarf shall be removed before fitting end closures. This will allow pipe to comply with the requirements of Technical Guidance Note 4 of the Water UK "Principles of Water Supply Hygiene".

11.2 Supply of Coils

Pipes shall be inspected prior to delivery to ensure that the coiling has not caused excessive ovality that

could compromise dimensions after delivery to site (section 7.5).

For sizes \geq 63 mm, all coils shall be securely banded with tough tape, which cannot be removed except by cutting. The banding operations are to be in accordance with the procedures and values given in Appendix C.

For smaller pipe sizes, coils may be supplied using shrink-fit, tough plastic film to hold the coil in place.

12. REFERENCES

British Standards

BS 1610	Materials testing machines and force verification equipment. Part 1: Grading of the forces applied by materials testing machines.
BS 2782	Methods of testing plastics: Measurements of dimensions of pipes
BS 3412	Polyethylene materials for moulding and extrusion
BS 5214	Testing machines for rubber and plastics. Part 1: Constant rate of traverse machines
BS 5252	Framework for colour co-ordination for building purposes
BS 6730	Specification for black polyethylene pipes up to nominal size 63 for above ground use for cold potable water
BS 6572	Specification for blue polyethylene pipes up to nominal size 63 for below ground use for potable water
BS EN ISO 179	Plastics – Determination of Charpy impact strength of rigid materials
BS EN ISO 9001	Quality Systems – Model for quality assurance in design/development, production, installation and servicing.
BS EN ISO 9002	Quality systems - Model for quality assurance in production and installation and servicing

BS EN 12106	Plastics piping systems - Polyethylene (PE) pipes - Test method for the resistance to internal pressure after application of squeeze-off
BS EN ISO 12162	Thermoplastic materials for pipes and fittings for pressure applications - Classification and designation – Overall service (design) coefficient
BS EN ISO 13478	Thermoplastics pipes for the conveyance of fluids – Determination of resistance to rapid crack propagation (RCP) - Full-scale test
BS EN ISO 13479	Polyolefin pipes for the conveyance of fluids – Determination of resistance to crack propagation – Test method for slow crack growth on notched pipes (notch test)

European Standards

prEN 12201	Plastics piping systems for water supply - Polyethylene (PE)
prEN 13244	Plastics piping systems for buried and above ground pressure systems for water for general purposes, drainage and sewerage - Polyethylene (PE)
EN 1056	Plastics piping and ducting systems - Plastics pipes and fittings – Test method for resistance to direct (natural) weathering.
EN 12118	Plastics piping systems - Determination of moisture content by coulometry
EN 13477	Determination of resistance to crack propagation - Small scale test (S4)

International Standards

ISO 161	Thermoplastics pipes for the conveyance of fluids - Nominal outside diameters and nominal pressures - Metric series
ISO 1133	Plastic – Determination of the melt mass-flow rate (MFR) and the melt volume-flow rate (MVR) of thermoplastics
ISO 1167	Thermoplastics pipes for the conveyance of fluids - Resistance to internal pressure – test method
ISO 1183	Plastics – Methods for determining the density and relative density of non-cellular plastics
ISO 4065	Thermoplastic pipes - Universal wall thickness table
ISO 4607	Plastics: Methods of exposure to natural weathering
ISO 6259	Thermoplastics pipes - determination of tensile properties and basic specifications - Part 1: General test method
ISO 6259	Thermoplastics pipes - Determination of tensile properties and basic specifications - Part 3: Polyolefin pipes
ISO 6964	Polyolefin pipes and fittings - Determination of carbon black content by calcination and pyrolysis - Test method and basic specification
ISO 11420	Method for assessment of carbon black dispersion in polyolefin pipes, fittings and compounds
ISO 11922	Thermoplastics pipes for the transport of fluids – Dimensions and tolerances - Part 1 : Metric series
ISO 13949	Method for the assessment of the degree of pigment dispersion in polyolefin pipes, fittings and compounds
ISO TR 9080	Thermoplastics pipes for the transport of fluids – Methods of extrapolation of hydrostatic stress rupture data to determine the long term hydrostatic strength of thermoplastics pipe materials

ISO TR 10837	Determination of the thermal stability of polyethylene (PE) for use in gas pipes and fittings
Other	
IGN 4-37-02	Design against surge and fatigue conditions for thermoplastic pipes
WIS 4-32-08	Specification for site fusion jointing of PE80 and PE100
IGN 4-32-18	The choice of pressure ratings of polyethylene pipes for water supply and sewerage duties (not yet published).

APPENDIX A CHARPY IMPACT TESTING METHODOLOGY

A.1 Apparatus for the Determination of Critical Strain Energy Release Rate G_c

A.1.1 Charpy pendulum test machine as described in 5.1 of BS EN ISO 179:1997

NOTE: The absorbed energy should be recorded preferably using a digital display or chart recorder.

A.1.2 Means of producing notches of variable depth across the test specimen. The resulting notch profile shall be $45^\circ \pm 15^\circ$ included angle and have a notch root radius of 10 μm or less.

A.1.3 Measuring apparatus for the determination of depth, thickness and crack depth to an accuracy of 0.01 mm.

A.2 Procedure

A.2.1 Test Piece Preparation

Sample testing by materials suppliers may be conducted on compression moulded sheet.

Testing of samples by pipe manufacturers shall be made on pieces cut from the bore sections of pipe walls.

Without heating or moulding prepare a minimum of 15 impact test pieces cut from the longitudinal direction of the pipe (see Figure A.1 and Figure A.2) having the dimensions specified in Table A.1.

Nominal pipe size	Test Temperature (°C)	Thickness B (mm) (± 0.2)	Depth D (mm) (± 0.15)	Length L (mm) (± 2)	Test span S (mm) (± 0.2)
>315 mm	23 (± 2)	12	12	100	70
>315 mm	0 (± 1)	2	10	80	40

Table A.1: Charpy specimen dimensions (mm)

Internal stress in the pipe may cause test pieces to curve when cut. If this occurs, cut strips from the full wall thickness and machine flat to the final

dimensions after the stress has been relieved e.g. 24 hours or longer elapsed time.

Machine the inside surface of each test piece first, to produce a flat smooth surface with the minimum removal of material, followed by the opposite surface. Trim the remaining surfaces to give the appropriate widths and approximate length.

NOTE: Woodworking planing machines have been found to give an adequate finish.

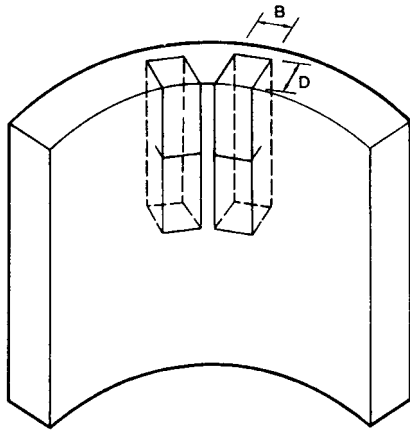

Figure A.1: Orientation and dimensions of impact specimens relative to pipe geometry

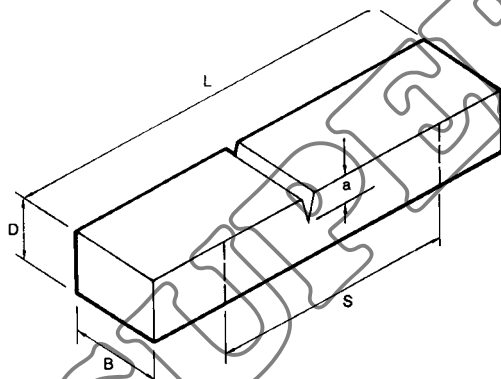

Figure A.2: Dimensions for Charpy impact specimen

Where:

- D= the depth of the impact specimen
- B= the impact specimen thickness
- L= the specimen length
- S= the test span
- a = the notch depth

A band saw should not be used unless followed by finishing. Circular sawing is preferable.

Machine a notch across the centre of the “internal bore” surface of each impact test piece to produce a

series of test pieces such that a range of Charpy calibration factor, ϕ , of approximately 0.1 to 0.5 is covered in approximately equal steps as shown in Table A.2 and Table A.3.

When testing at 23°C, condition the specimens at (23 ± 2)°C for 24 hours prior to testing.

When testing at 0°C, condition the specimens at (0 ± 1)°C for at least 2 hours prior to testing.

Measure the average thickness B and depth D of each test piece adjacent to the notch and also the notch depth measured from the side.

A.2.2 Impact test procedure

Ensure that the test apparatus is level and correctly aligned for the test span as defined in Table A.1. By performing preliminary tests ensure that the tup to be used provides the appropriate impact energy for the material (within 20-60 % of the indicated range) and that the impact machine produces accurate readings within permissible error limitations as specified in BS EN ISO 179:1997.

The test velocity should be chosen to maintain the strain rate of the test within a range of 30 to 100 reciprocal seconds (over which Gc has been found to be essentially independent of strain rate) calculated from the following formula:

$$E = \frac{6DV}{S^2}$$

Where:

- E = strain rate (s⁻¹)
- D = test piece depth (m)
- S = test span (m)
- V = velocity of tup at impact (ms⁻¹)

For the specimen dimensions given in Table A.1 a velocity of 2.90 ms⁻¹ is appropriate.

Place the test pieces in turn centrally on the supports with the notch facing away from the tup and centre the notch as shown in Figure A.3. It is essential that uniform contact is achieved between the test piece and the vertical supports. Release the tup and record the impact energy absorbed in breaking each test piece, applying corrections for frictional losses etc where necessary.

